

DUCT ELECTRICAL HEATER

EKH 100	EKH 250	EKH 400×200	EKH 700×400
EKH 125	EKH 315	EKH 500×250	EKH 800×500
EKH 150		EKH 500×300	EKH 900×500
EKH 160		EKH 600×300	EKH 1000×500
EKH 200		EKH 600×350	

EN USER'S MANUAL

CONTENTS

Safety requirements.....	2
Purpose.....	4
Delivery set.....	4
Designation key.....	4
Technical data.....	5
Design and operating principle	11
Mounting and set-up.....	12
Connection to power mains	14
Technical maintenance.....	21
Storage and transportation regulations.....	21
Manufacturer's warranty	22
Certificate of acceptance.....	23
Seller information.....	23
Installation certificate.....	23
Warranty card.....	23

This user's manual is a main operating document intended for technical, maintenance, and operating staff.

The manual contains information about purpose, technical details, operating principle, design, and installation of the EKH unit and all its modifications.

Technical and maintenance staff must have theoretical and practical training in the field of ventilation systems and should be able to work in accordance with workplace safety rules as well as construction norms and standards applicable in the territory of the country.

SAFETY REQUIREMENTS

All user's manual requirements as well as the provisions of all the applicable local and national construction, electrical, and technical norms and standards must be observed when installing and operating the unit.

Disconnect the fan from power supply prior to any connection, servicing and repair operations.

Only qualified electricians with a work permit for electrical units up to 1000 V are allowed for installation and The present user's manual should be carefully read before beginning works.

Check the unit for any visible damages of the casing before starting installation. The casing internals must be free of any foreign objects.

While mounting the unit, avoid compression of the casing!

Misuse of the unit and any unauthorized modifications are not allowed.

Do not expose the unit to adverse atmospheric agents (rain, sun, etc.).

Transported air must not contain any dust or other solid impurities, sticky substances, or fibrous materials.

Do not use the unit in a hazardous or explosive environment containing spirits, gasoline, insecticides, etc.

Do not close or block the intake or extract vents in order to ensure the efficient air flow.

Do not sit on the unit and do not put objects on it.

The information in this user's manual was correct at the time of the document's preparation. The Company reserves the right to modify the technical characteristics, design, or configuration of its products at any time in order to incorporate the latest technological developments.

Do not touch the unit with wet or damp hands.

Do not touch the unit when barefoot.

This unit is not intended for use by persons (including children) with reduced physical, sensory or mental capabilities, or lack of experience and knowledge, unless they have been given supervision or instruction concerning use of the unit by a person responsible for their safety. Children should be supervised to ensure that they do not play with the unit.

This appliance can be used by children aged from 8 years and above and persons with reduced physical, sensory or mental capabilities or lack of experience and knowledge if they have been given supervision or instruction concerning use of the appliance in a safe way and understand the hazards involved.

Cleaning and user maintenance shall not be done by children without supervision.

Children shall not play with the appliance.

CAUTION: In order to avoid a safety hazard due to inadvertent resetting of the thermal cut-out, this unit must not be supplied through an external switching device, such as a timer, or connected to a circuit that is regularly switched on and off by the utility.



**THE PRODUCT MUST BE DISPOSED SEPARATELY AT THE END OF ITS SERVICE LIFE.
DO NOT DISPOSE THE UNIT AS UNSORTED DOMESTIC WASTE.**

PURPOSE

Duct heaters are designed for heating of intake fresh air transported through the ventilating system.

The unit is a component part and is not designed for independent operation.

The heater is designed for extended periods of continuous operation without disconnection from the power mains.

Transported air must not contain any flammable or explosive mixtures, evaporation of chemicals, sticky substances, fibrous materials, coarse dust, soot and oil particles or environments favourable for the formation of hazardous substances (toxic substances, dust, pathogenic germs).

DELIVERY SET

Name	Number
Heater	1
User's manual	1

DESIGNATION KEY

EKH 100- 0.6

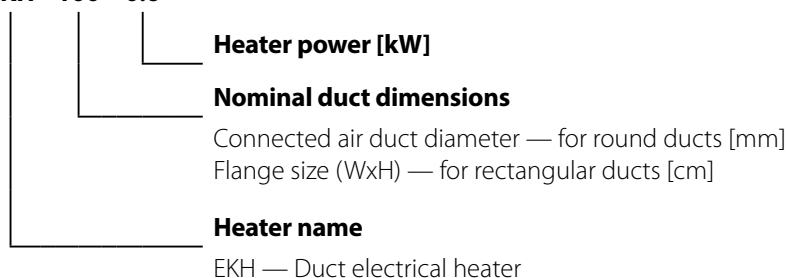

Designation example:

EKH 315-9.0-3 – heater with branch pipe diameter 315 mm, power 9 kW.

EKH 40x20-4.5 heater for a rectangular duct 400x200 mm, power 4,5 kW.

The basic heater overall dimensions must correspond to the ones provided in the tables «Overall and connecting dimensions».

The basic heater parameters and thermal dynamic characteristics are shown in the tables «Main technical parameters».

TECHNICAL DATA

The unit is designed for indoor application at ambient temperature from -30 °C up to +50 °C and relative humidity up to 80 %.

The heater is rated as a class I electric appliance.

Ingress protection rating against access to hazardous parts and water ingress is IP40.

The heater design is constantly improved, so some models may slightly differ from the ones depicted herein.

OVERALL AND CONNECTING DIMENSIONS OF HEATERS FOR ROUND DUCTS

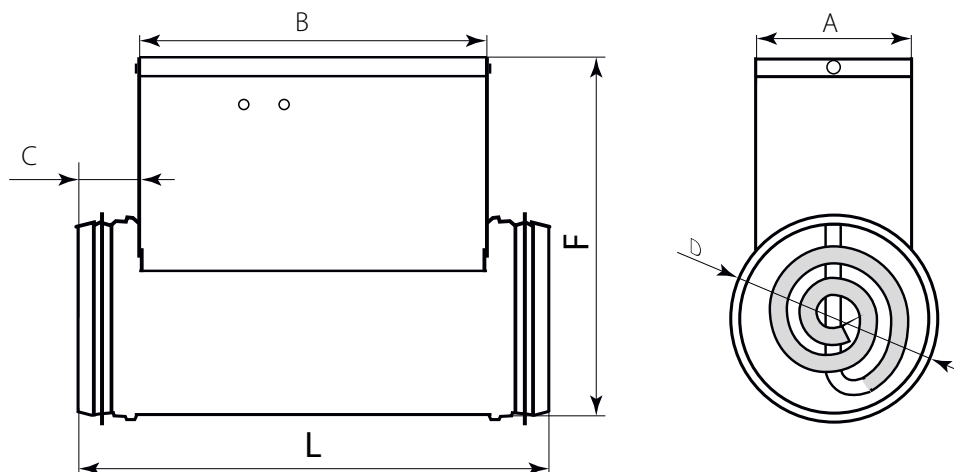

Heater model	Dimensions [mm]					
	D	L	B	F	C	A
EKH 100-0.6	99	306	226	207	40	94
EKH 100-0.8	99	306	226	207	40	94
EKH 100-1.2	99	306	226	207	40	94
EKH 100-1.6	99	306	226	207	40	94
EKH 100-1.8-1	99	376	296	207	40	94
EKH 125-0.6	124	306	226	230	40	103
EKH 125-0.8-1	124	306	226	230	40	103
EKH 125-1.2	124	306	226	230	40	103
EKH 125-1.6	124	306	226	230	40	103
EKH 125-2.4	124	376	296	230	40	103
EKH 150-1.2	149	306	226	255	40	120
EKH 150-1.7	149	306	226	255	40	120
EKH 150-2.0	149	306	226	255	40	120
EKH 150-2.4	149	306	226	255	40	120
EKH 150-3.4	149	306	226	255	40	120
EKH 150-3.6	149	376	296	255	40	120
EKH 150-5.1	149	376	296	255	40	120
EKH 150-6.0	149	376	296	255	40	120

Heater model	Dimensions [mm]					
	D	L	B	F	C	A
EKH 160-1.2	159	306	226	267	40	120
EKH 160-1.7	159	306	226	267	40	120
EKH 160-2.0	159	306	226	267	40	120
EKH 160-2.4	159	306	226	267	40	120
EKH 160-3.4	159	306	226	267	40	120
EKH 160-3.6	159	376	296	267	40	120
EKH 160-5.1	159	376	296	267	40	120
EKH 160-6.0	159	376	296	267	40	120
EKH 200-1.2	199	294	214	302	40	150
EKH 200-1.7	199	294	214	302	40	150
EKH 200-2.0	199	294	214	302	40	150
EKH 200-2.4	199	294	214	302	40	150
EKH 200-3.4	199	294	214	302	40	150
EKH 200-3.6	199	376	296	302	40	150
EKH 200-5.1	199	376	296	302	40	150
EKH 200-6.0	199	376	296	302	40	150
EKH 250-1.2	249	306	226	356	40	150
EKH 250-2.0	249	306	226	356	40	150
EKH 250-2.4	249	306	226	356	40	150
EKH 250-3.0	249	306	226	356	40	150
EKH 250-3.6	249	376	296	356	40	150
EKH 250-6.0	249	376	296	356	40	150
EKH 250-9.0	249	376	296	356	40	150
EKH 315-1.2	313	294	214	425	40	150
EKH 315-2.0	313	294	214	425	40	150
EKH 315-2.4	313	294	214	425	40	150
EKH 315-3.6	313	376	296	425	40	150
EKH 315-6.0	313	376	296	425	40	150
EKH 315-9.0	313	376	296	425	40	150

MAIN TECHNICAL PARAMETERS OF HEATERS FOR ROUND DUCTS

Heater model	Power [kW]	Number of phases	Voltage [V]	Number of electric heating elements x power [kW]	Current [A]	Minimum air flow [m ³ /h]	Weight [kg]
EKH 100-0.6	0.6	1	230	1x0.6	2.6	60	1.3
EKH 100-0.8	0.8	1	230	1x0.8	3.5	80	1.3
EKH 100-1.2	1.2	1	230	2x0.6	5.2	90	1.5
EKH 100-1.6	1.6	1	230	2x0.8	7.0	120	1.5
EKH 100-1.8	1.8	1	230	3x0.6	7.8	130	1.7
EKH 125-0.6	0.6	1	230	1x0.6	2.6	60	1.4
EKH 125-0.8	0.8	1	230	1x0.8	3.5	80	1.4
EKH 125-1.2	1.2	1	230	2x0.6	5.2	90	1.7
EKH 125-1.6	1.6	1	230	2x0.8	7.0	120	1.7
EKH 125-2.4	2.4	1	230	3x0.8	7.8	150	1.9
EKH 150-1.2	1.2	1	230	1x1.2	5.2	120	2.0
EKH 150-1.7	1.7	1	230	1x1.7	7.4	130	2.0
EKH 150-2.0	2.0	1	230	1x2.0	8.7	140	2.0
EKH 150-2.4	2.4	1	230	2x1.2	10.4	150	2.4
EKH 150-3.4	3.4	1	230	2x1.7	14.7	220	2.4
EKH 150-3.6	3.6	3	400	3x1.2	5.2	265	2.8
EKH 150-5.1	5.1	3	400	3x1.7	7.4	320	2.8
EKH 150-6.0	6.0	3	400	3x2.0	8.7	360	2.8
EKH 160-1.2	1.2	1	230	1x1.2	5.2	150	2.1
EKH 160-1.7	1.7	1	230	1x1.7	7.4	160	2.1
EKH 160-2.0	2.0	1	230	1x2.0	8.7	170	2.1
EKH 160-2.4	2.4	1	230	2x1.2	10.4	180	2.5
EKH 160-3.4	3.4	1	230	2x1.7	14.8	250	2.5
EKH 160-3.6	3.6	3	400	3x1.2	5.2	265	3.0
EKH 160-5.1	5.1	3	400	3x1.7	7.4	375	3.0
EKH 160-6.0	6.0	3	400	3x2.0	8.7	440	3.0
EKH 200-1.2	1.2	1	230	1x1.2	5.2	150	2.5
EKH 200-1.7	1.7	1	230	1x1.7	7.4	160	2.5
EKH 200-2.0	2.0	1	230	1x2.0	8.7	170	2.5
EKH 200-2.4	2.4	1	230	2x1.2	10.4	180	3.0
EKH 200-3.4	3.4	1	230	2x1.7	14.8	250	3.0
EKH 200-3.6	3.6	3	400	3x1.2	5.2	265	3.5
EKH 200-5.1	5.1	3	400	3x1.7	7.4	375	3.5
EKH 200-6.0	6.0	3	400	3x2.0	8.7	440	3.5
EKH 250-1.2	1.2	1	230	1x1.2	5.2	180	3.2
EKH 250-2.0	2.0	1	230	1x2.0	8.7	200	3.2
EKH 250-2.4	2.4	1	230	2x1.2	10.4	265	3.7
EKH 250-3.0	3.0	1	230	1x3.0	13.0	375	3.2
EKH 250-3.6	3.6	3	400	3x1.2	5.2	375	4.6
EKH 250-6.0	6.0	3	400	3x2.0	8.7	440	4.6
EKH 250-9.0	9.0	3	400	3x3.0	13.0	660	4.6
EKH 315-1.2	1.2	1	230	1x1.2	5.2	180	4.0
EKH 315-2.0	2.0	1	230	1x2.0	8.7	200	4.0
EKH 315-2.4	2.4	1	230	2x1.2	10.4	265	4.8
EKH 315-3.6	3.6	3	400	3x1.2	5.2	375	5.6
EKH 315-6.0	6.0	3	400	3x2.0	8.7	440	5.6
EKH 315-9.0	9.0	3	400	3x3.0	13.0	660	5.6

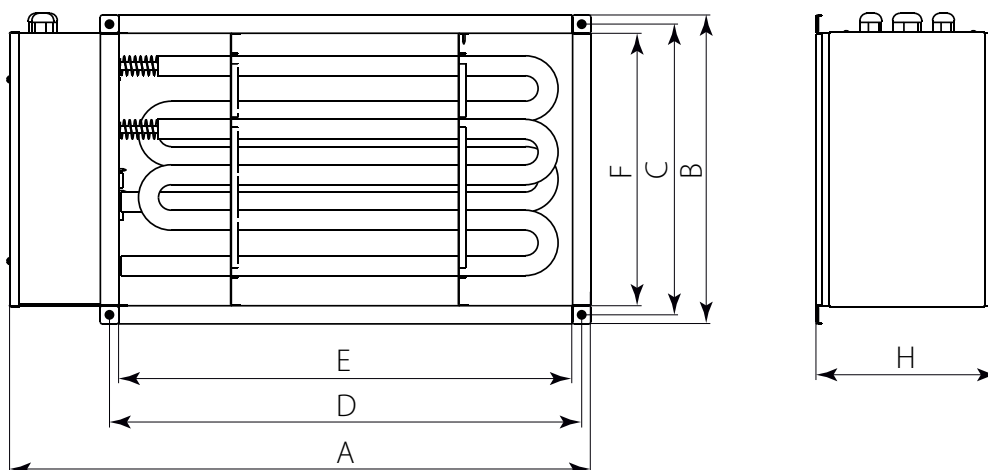

OVERALL AND CONNECTING DIMENSIONS OF HEATERS FOR RECTANGULAR DUCTS

Heater model	Dimensions [mm]						
	A	B	D	C	E	F	H
EKH 40x20-4.5	540	240	420	220	400	200	200
EKH 40x20-6	540	240	420	220	400	200	200
EKH 40x20-7.5	540	240	420	220	400	200	200
EKH 40x20-9	540	240	420	220	400	200	200
EKH 40x20-10.5	540	240	420	220	400	200	200
EKH 40x20-12	540	240	420	220	400	200	200
EKH 40x20-15	540	240	420	220	400	200	200
EKH 50x25-6	640	290	520	270	500	250	200
EKH 50x25-7.5	640	290	520	270	500	250	200
EKH 50x25-9	640	290	520	270	500	250	200
EKH 50x25-10.5	640	290	520	270	500	250	200
EKH 50x25-12	640	290	520	270	500	250	200
EKH 50x25-15	640	290	520	270	500	250	200
EKH 50x25-18	640	290	520	270	500	250	200
EKH 50x25-21	640	290	520	270	500	250	200
EKH 50x30-6	640	340	520	320	500	250	200
EKH 50x30-7.5	640	340	520	320	500	300	200
EKH 50x30-9	640	340	520	320	500	300	200
EKH 50x30-10.5	640	340	520	320	500	300	200
EKH 50x30-12	640	340	520	320	500	300	200
EKH 50x30-15	640	340	520	320	500	300	200
EKH 50x30-18	640	340	520	320	500	300	200

Heater model	Dimensions [mm]						
	A	B	D	C	E	F	H
EKH 50x30-21	640	340	520	320	500	300	200
EKH 60x30-9	740	340	620	320	600	300	200
EKH 60x30-12	740	340	620	320	600	300	200
EKH 60x30-15	740	340	620	320	600	300	200
EKH 60x30-18	740	340	620	320	600	300	200
EKH 60x30-21	740	340	620	320	600	300	200
EKH 60x30-24	740	340	620	320	600	300	200
EKH 60x35-9	740	390	620	370	600	350	200
EKH 60x35-12	740	390	620	370	600	350	200
EKH 60x35-15	740	390	620	370	600	350	200
EKH 60x35-18	740	390	620	370	600	350	200
EKH 60x35-21	740	390	620	370	600	350	200
EKH 60x35-24	740	390	620	370	600	350	200
EKH 70x40-18	840	440	720	420	700	400	390
EKH 70x40-27	840	440	720	420	700	400	510
EKH 70x40-36	840	440	720	420	700	400	750
EKH 80x50-27	940	540	820	520	800	500	390
EKH 80x50-36	940	540	820	520	800	500	510
EKH 80x50-54	940	540	820	520	800	500	750
EKH 90x50-45	1040	540	920	520	900	500	750
EKH 90x50-54	1040	540	920	520	900	500	750
EKH 100x50-45	1140	540	1020	520	1000	500	750
EKH 100x50-54	1140	540	1020	520	1000	500	750

MAIN TECHNICAL PARAMETERS OF HEATERS FOR RECTANGULAR DUCTS

Heater model	Power [kW]	Number of phases	Voltage [V]	Number of electric heating elements x power [kW]	Current [A]	Minimum air flow [m ³ /h]	Weight [kg]
EKH 40x20-4.5	4.5	3	400	3x1.5	6.5	330	6.5
EKH 40x20-6	6.0	3	400	3x2.0	8.7	440	6.5
EKH 40x20-7.5	7.5	3	400	3x2.5	10.9	550	6.5
EKH 40x20-9	9.0	3	400	3x3.0	13.0	660	6.5
EKH 40x20-10.5	10.5	3	400	3x3.5	15.2	770	6.5
EKH 40x20-12	12.0	3	400	3x4.0	17.4	880	6.5
EKH 40x20-15	15.0	3	400	3x5.0	21.7	1100	6.5
EKH 50x25-6	6.0	3	400	3x2.0	8.7	440	7.65
EKH 50x25-7.5	7.5	3	400	3x2.5	10.9	550	7.65
EKH 50x25-9	9.0	3	400	3x3.0	13.0	660	7.65
EKH 50x25-10.5	10.5	3	400	3x3.5	15.2	770	7.65
EKH 50x25-12	12.0	3	400	3x4.0	17.4	880	7.65
EKH 50x25-15	15.0	3	400	3x5.0	21.7	1100	7.65
EKH 50x25-18	18.0	3	400	3x6.0	26.0	1320	7.65
EKH 50x25-21	21.0	3	400	3x7.0	30.0	1540	7.65
EKH 50x30-6	6.0	3	400	3x2.0	8.7	440	8.2
EKH 50x30-7.5	7.5	3	400	3x2.5	10.9	550	8.2
EKH 50x30-9	9.0	3	400	3x3.0	13.0	660	8.2
EKH 50x30-10.5	10.5	3	400	3x3.5	15.2	770	8.2
EKH 50x30-12	12.0	3	400	3x4.0	17.4	880	8.2
EKH 50x30-15	15.0	3	400	3x5.0	21.7	1100	8.2
EKH 50x30-18	18.0	3	400	3x6.0	26.0	1320	8.2
EKH 50x30-21	21.0	3	400	3x7.0	30.0	1540	8.2
EKH 60x30-9	9.0	3	400	3x3.0	13.0	660	9.4
EKH 60x30-12	12.0	3	400	3x4.0	17.4	880	9.4
EKH 60x30-15	15.0	3	400	3x5.0	21.7	1100	9.4
EKH 60x30-18	18.0	3	400	3x6.0	26.0	1320	9.4
EKH 60x30-21	21.0	3	400	3x7.0	30.0	1540	9.4
EKH 60x30-24	24.0	3	400	3x8.0	34.7	1760	9.4
EKH 60x35-9	9.0	3	400	3x3.0	13.0	660	9.75
EKH 60x35-12	12.0	3	400	3x4.0	17.4	880	9.75
EKH 60x35-15	15.0	3	400	3x5.0	21.7	1100	9.75
EKH 60x35-18	18.0	3	400	3x6.0	26.0	1320	9.75
EKH 60x35-21	21.0	3	400	3x7.0	30.0	1540	9.75
EKH 60x35-24	24.0	3	400	3x8.0	34.7	1760	9.75
EKH 70x40-18	18.0	3	400	6x3.0	26.0	1320	14
EKH 70x40-27	27.0	3	400	9x3.0	39.0	1980	18.5
EKH 70x40-36	36.0	3	400	12x3.0	52.0	2640	25
EKH 80x50-27	27.0	3	400	9x3.0	39.0	1980	19
EKH 80x50-36	36.0	3	400	12x3.0	52.0	2640	23.5
EKH 80x50-54	54.0	3	400	18x3.0	78.0	3960	30
EKH 90x50-45	45.0	3	400	15x3.0	65.0	3300	31
EKH 90x50-54	54.0	3	400	18x3.0	78.0	3960	33.5
EKH 100x50-45	45.0	3	400	15x3.0	65.0	3300	33
EKH 100x50-54	54.0	3	400	18x3.0	78.0	3960	36

The allowable power supply voltage deviations from the rated voltage shown in the tables above is +10 %.

DESIGN AND OPERATING PRINCIPLE

The heaters (see the figure below) consist of a casing with a rigidly fixed connecting box that is with the removable cover.

The tight seals are located at the external side of the connection box for routing of supply, control and ground cables.

The heating elements are located inside the casing.

The casing, the connection box and the heater cover are made of galvanized steel.

The connection box incorporates:

- terminal block for connection of external supply and control circuits of the heater;
- screw ground terminal;
- thermal switches (automatic and manual).

The heaters are equipped with two overheating sensors - thermal switches:

- with automatic reset and temperature threshold value 50 °C;
- with manual reset and temperature threshold value 90 °C.

Thermal switch with manual reset is equipped with a button for manual restart. The label **RESTART** is near the button.

The electric heater wiring diagram is shown at the internal wall of the connecting box.

EKH HEATER FOR ROUND DUCTS

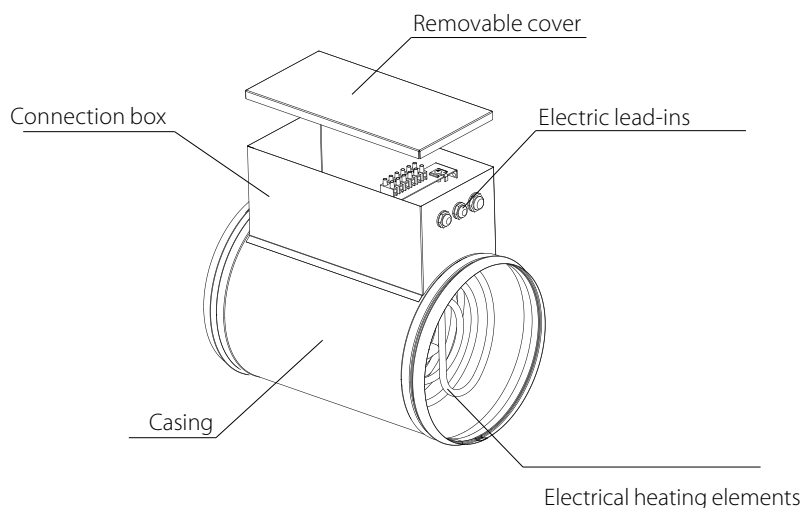

EKH HEATER FOR RECTANGULAR DUCTS

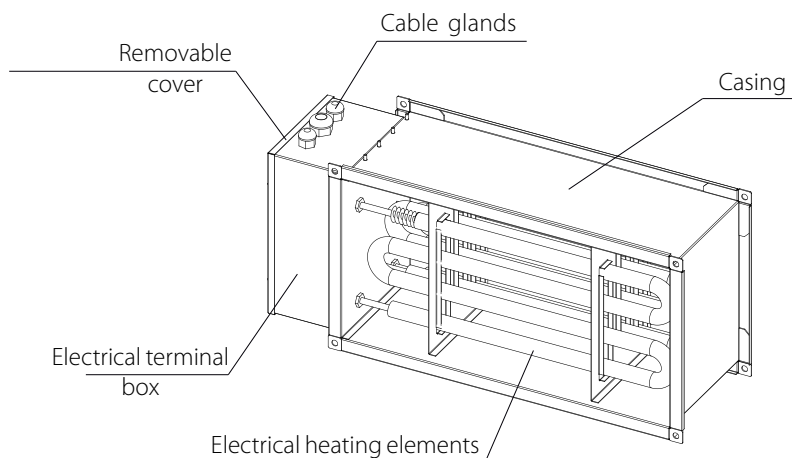

MOUNTING AND SET-UP



READ THE USER'S MANUAL BEFORE INSTALLING THE UNIT

Disconnect the unit from power supply prior to any connection, servicing and repair operations.

Prior to the heater installation check the heater for the integrity and reliability of the heating element fixation. The heater shall be installed in the air duct with the same diameter (dimensions).

The working position of the heater must ensure unimpeded access to the connection box and the RESET thermoswitch manual reset button.

The heater must be securely fastened in place. The mounting location must enable quick access to the heater and provide ample space for technical maintenance operations.

The duct heaters are designed for min. air flow speed 1,5 m/s and max. exhaust air temperature 40 °C.

The rectangular heaters are to install in such a way that the arrow on the casing indicates the air flow direction.

The minimum clearance between the heater and other ventilation system components should at least double the connection size (for the heaters with round air ducts) or double the diagonal cut (for the heaters with rectangular air ducts).

Do not insulate the heaters against heat! No inflammable, explosive or fire-hazardous materials are allowed within 150 mm of the heater casing and within 500 mm of the heater air inlet and outlet. Air ducts and fans must be equipped with a grille or similar protective device preventing free access to the electric heating elements.

The supply voltage must be fed via an automatic circuit breaker with a minimum gap of 3 mm between the open contacts on all poles. The circuit breaker must be integrated into the stationary wiring in accordance with the applicable electrical wiring regulations.

The air filter shall be installed upstream of the heater to protect it from dust and dirt. The distance between the filter and the heater shall be long enough as the close filter location to the heater is not allowed due to fire safety reasons.

Pre-commissioning precautions:

- The unit must be safely grounded in compliance with the «Regulations for Electrical Installation» (i.e. the clamp must be connected to the protective ground wire);
- Power to the electrical heater is supplied only when the fan is running;
- Electric heater power cut-off is allowed only when the fan is running, the time span between the heater power cut-off and the fan turn-off shall be at least 30 seconds;
- The minimum air flow through the heater must comply with the value stated in the technical specification.

To ensure proper and safe operation the heater should be equipped with an automatic control system capable of comprehensive control and protection - in particular:

- automatic control of power and air heating temperature control;
- monitoring the filter condition using the pressure differential sensor feedback;
- powering off the heater in the event of the supply fan shutdown or air flow velocity drop as well as upon actuation of the built-in overheating protection thermostats;
- ventilation system shutdown after complete cooling of heating elements.

In the course of operation, the triggering of thermostats with automatic reset may occur.

The thermostats may be triggered by an unexpected power failure or an incompatibility between the chosen heater and the air flow rate. The thermostats are to interrupt the power supply until the heater cools down to the room temperature.

The thermostat with manual reset may be triggered in the heater supplied with power if the air flow is absent (emergency operation) or the air flow rates are too low (below the minimum nominal rate).

In case of triggering of the thermostat with manual reset:

- interrupt the power supply to the heater;
- rectify the fault in the ventilation system;
- remove the cover from the connection box and press the RESET button to restore the switch to the original position.

CONNECTING ROUND AIR DUCTS TO THE HEATER

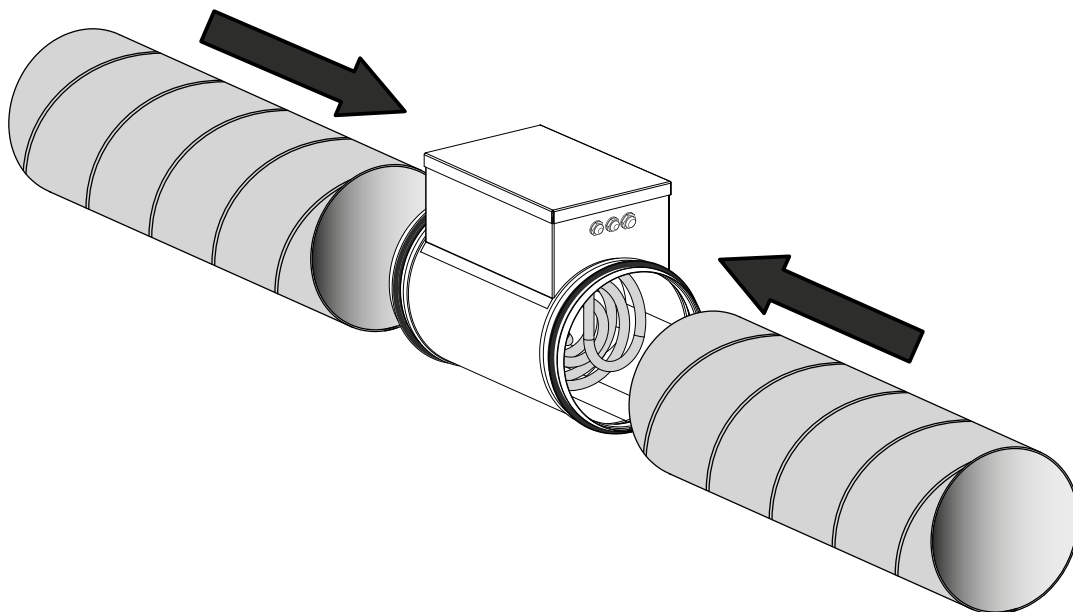

The heater is designed for internal installation into air ducts in the horizontal or vertical position. In a horizontal position the connection box must face upwards. Permitted deviation up to 90°. The heater must not be mounted with the connection box suspended downwards (risk of condensate leaking and short circuit of power grid).

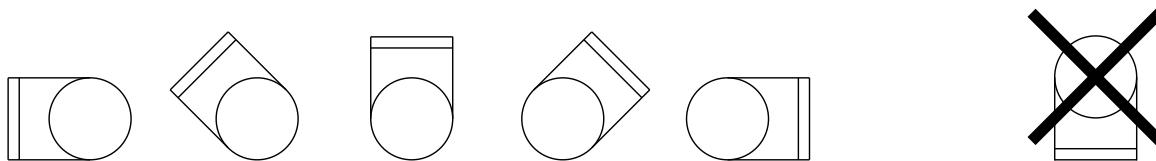

CONNECTING RECTANGULAR AIR DUCTS TO THE HEATER

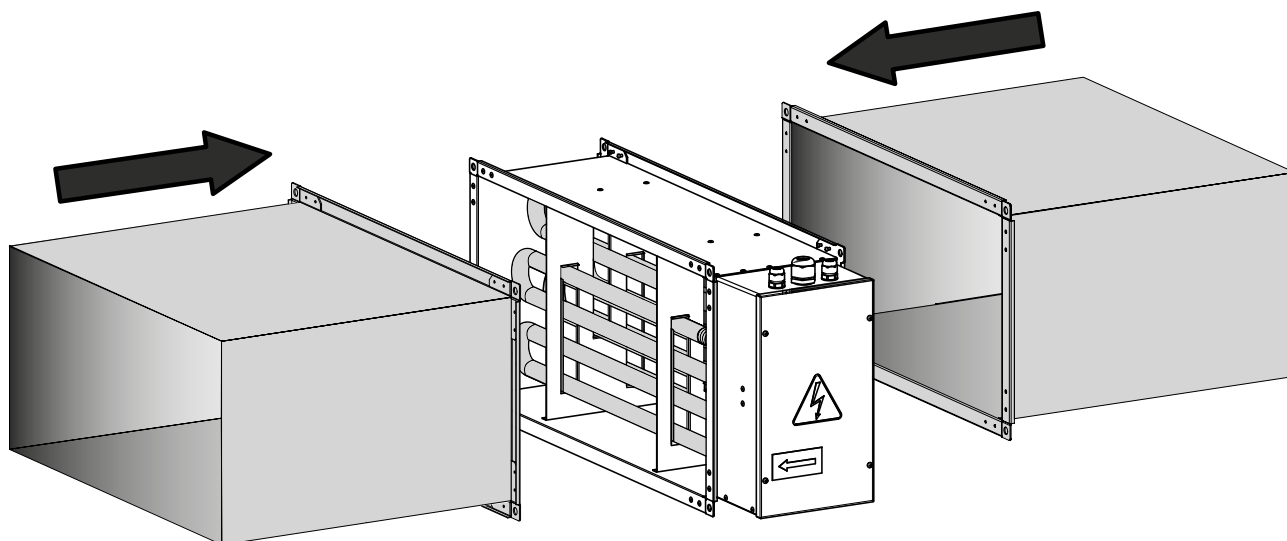

CONNECTION TO POWER MAINS



**POWER OFF THE POWER SUPPLY PRIOR TO ANY OPERATIONS WITH THE UNIT.
THE UNIT MUST BE CONNECTED TO POWER SUPPLY BY A QUALIFIED ELECTRICIAN.
THE RATED ELECTRICAL PARAMETERS OF THE UNIT ARE GIVEN ON THE
MANUFACTURER'S LABEL.**



**ANY TAMPERING WITH THE INTERNAL CONNECTIONS IS PROHIBITED
AND WILL VOID THE WARRANTY.**

The heaters have to be connected to the single-phase AC mains with voltage of 230 V/ 50 Hz or three-phase AC mains with voltage of 400 V/ 50 Hz dependent on the heater model.

The electric connections must be performed with insulated, durable and heat-resistant conductors (cables, wires) with a matching cross section. The external lead-in (230 V/50 Hz or 400 V/50 Hz) must be equipped with an automatic circuit breaker built into the stationary wiring to interrupt all the network phases in case of a short circuit or an overload.

The location of the QF external switch must ensure free access for quick shutdown of the unit. The protection trip current must be consistent with the maximum current consumption of the unit (see the tables of main technical parameters).

The cross section selection must account for the maximum permissible wire heating which depends on the wire type, its insulation, length and installation method (i.e. overhead, in pipes or inside walls).

Wiring diagram types are determined by quantity of the heating elements, supply voltage characteristics, number of phases.

Wiring diagram designation key:

- S1, S2** – thermal switches
- En** – electrical heating elements
- X1** – terminal block
- X2** – ground clamp

WIRING DIAGRAM OF THE HEATER WITH ONE ELECTRICAL HEATING ELEMENT AND SINGLE-PHASE POWER SUPPLY

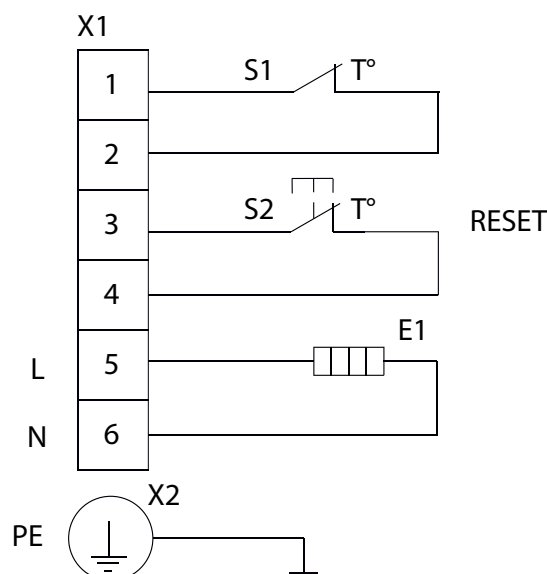

WIRING DIAGRAM OF THE HEATER WITH TWO ELECTRICAL HEATING ELEMENTS AND SINGLE-PHASE POWER SUPPLY

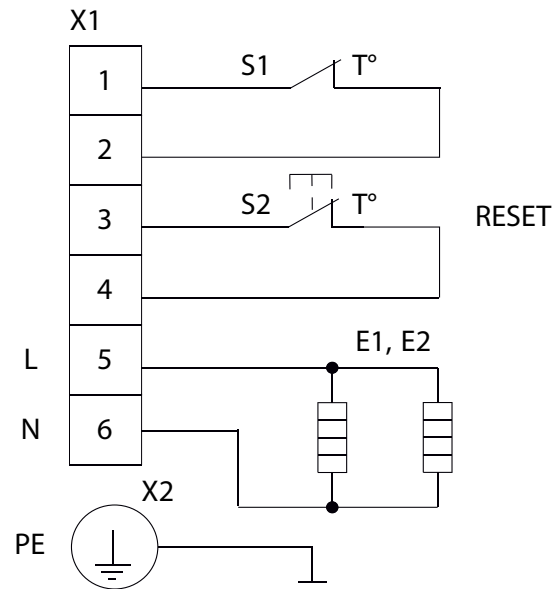

WIRING DIAGRAM OF THE HEATER WITH THREE ELECTRICAL HEATING ELEMENTS AND SINGLE-PHASE POWER SUPPLY

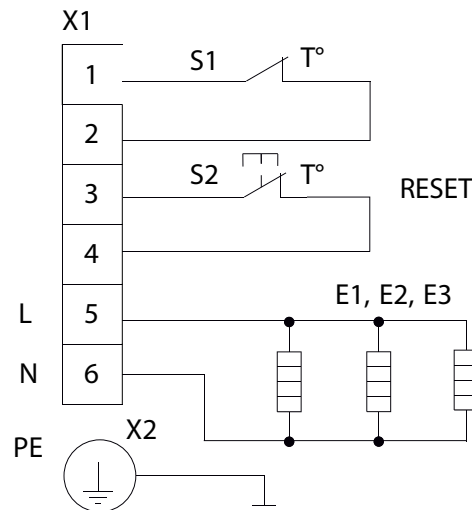

WIRING DIAGRAM OF THE HEATER WITH THREE ELECTRICAL HEATING ELEMENTS AND THREE-PHASE POWER SUPPLY

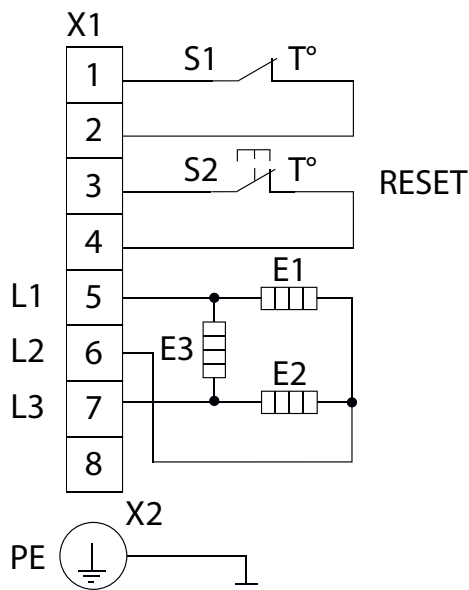
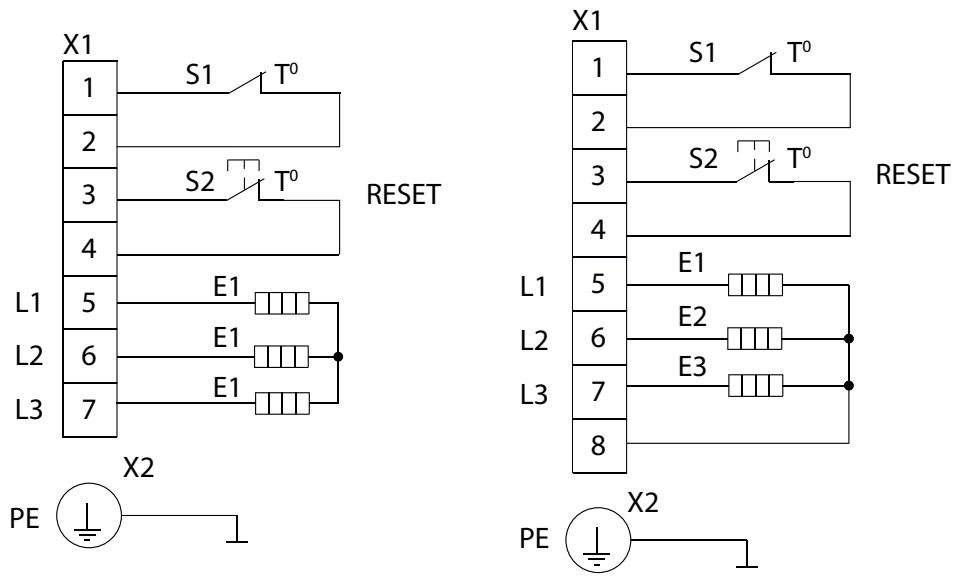

WIRING DIAGRAM OF THE HEATER WITH NINE ELECTRICAL HEATING ELEMENTS AND THREE-PHASE POWER SUPPLY, STAR CONNECTION AND THERMAL PROTECTION CONTACTS LEADED OUTSIDE

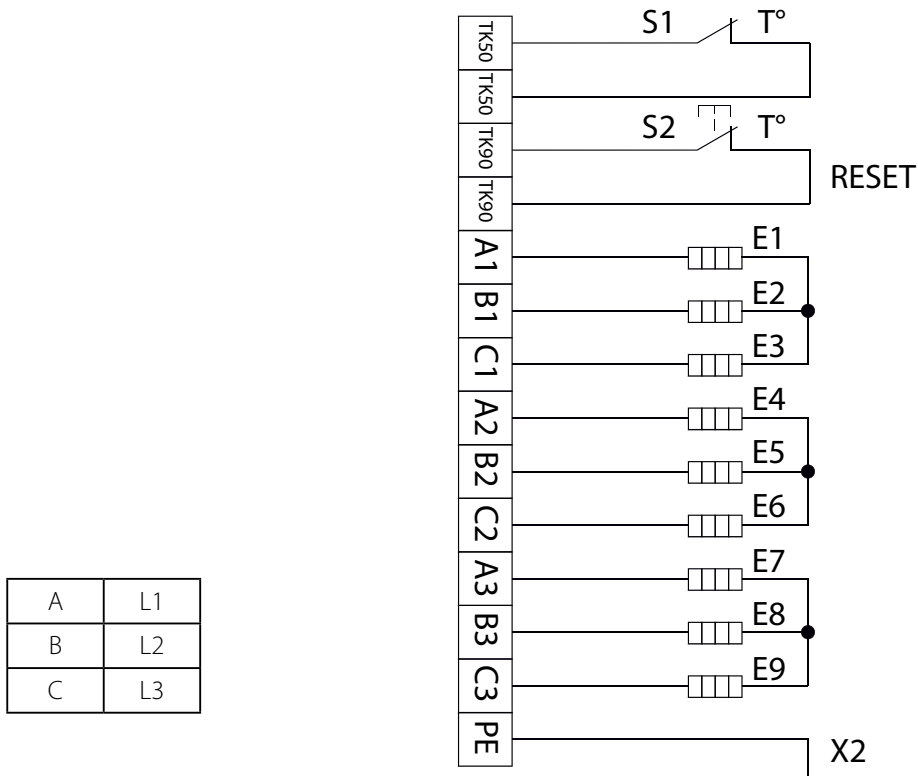

WIRING DIAGRAM OF THE HEATER WITH NINE ELECTRICAL HEATING ELEMENTS, THREE-PHASE POWER SUPPLY, DELTA CONNECTION AND THERMAL PROTECTION CONTACTS LEADED OUTSIDE

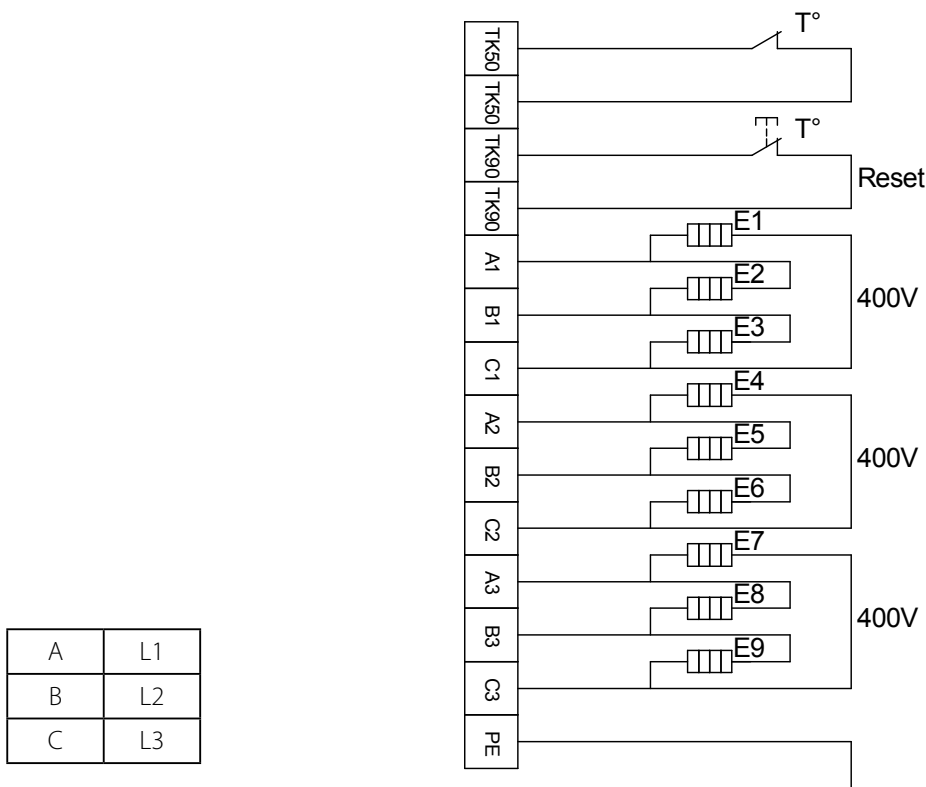

WIRING DIAGRAM OF THE HEATER WITH SIX ELECTRICAL HEATING ELEMENTS, THREE-PHASE POWER SUPPLY, DELTA CONNECTION AND THERMAL PROTECTION CONTACTS LEADED OUTSIDE

A	L1
B	L2
C	L3

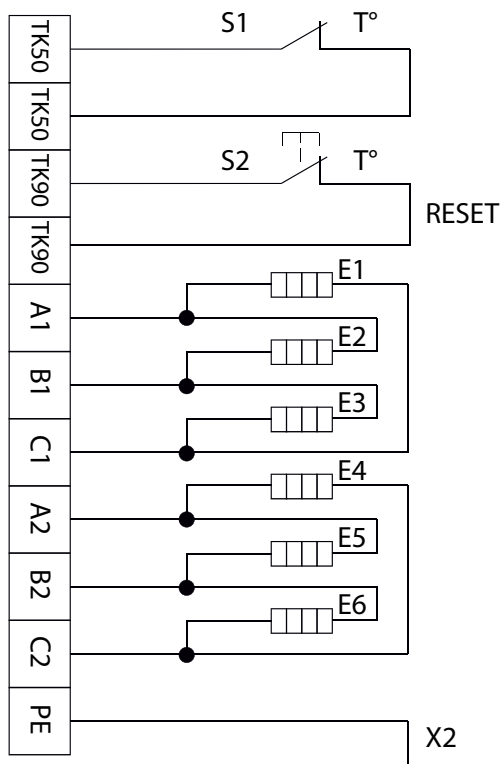

WIRING DIAGRAM OF THE HEATER WITH ONE ELECTRICAL HEATING ELEMENT, SINGLE-PHASE POWER SUPPLY AND TIME-DELAY RELAY

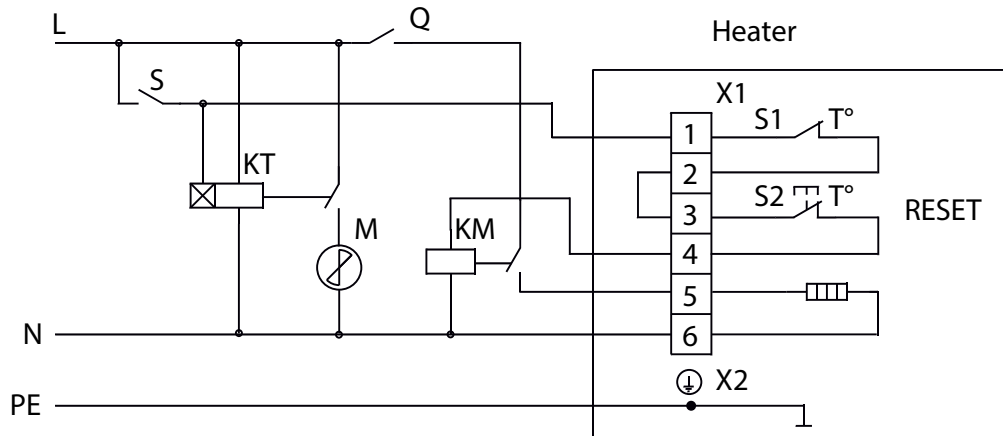

WIRING DIAGRAM OF THE RECTANGULAR HEATER WITH THREE ELECTRICAL HEATING ELEMENTS, THREE-PHASE POWER SUPPLY, STAR CONNECTION AND TIME-DELAY RELAY

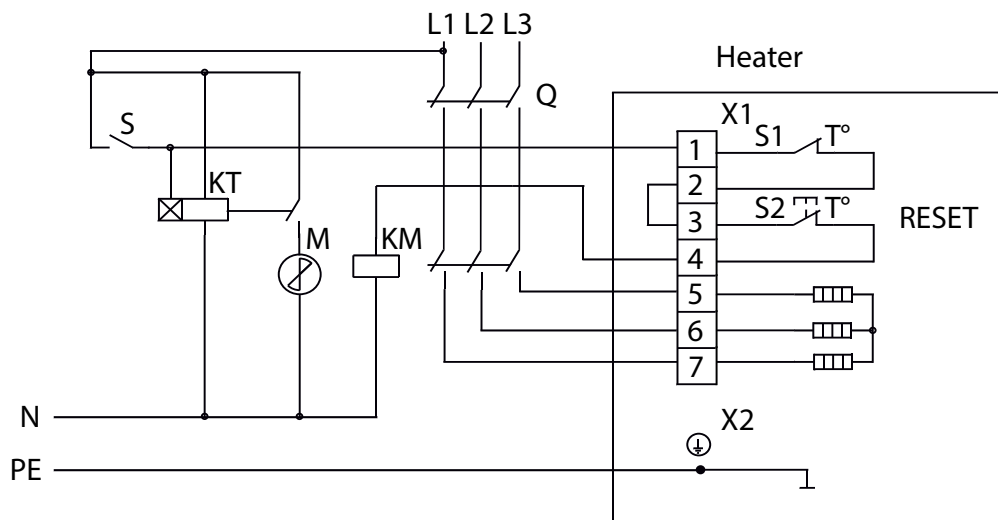

- S** – ON/OFF switch
- KT** – time-delay relay
- M** – fan
- KM** – magnetic starter
- Q** – automatic circuit breaker

WIRING DIAGRAM OF THE RECTANGULAR HEATER WITH THREE ELECTRICAL HEATING ELEMENTS, THREE-PHASE POWER SUPPLY, DELTA CONNECTION AND TIME-DELAY RELAY

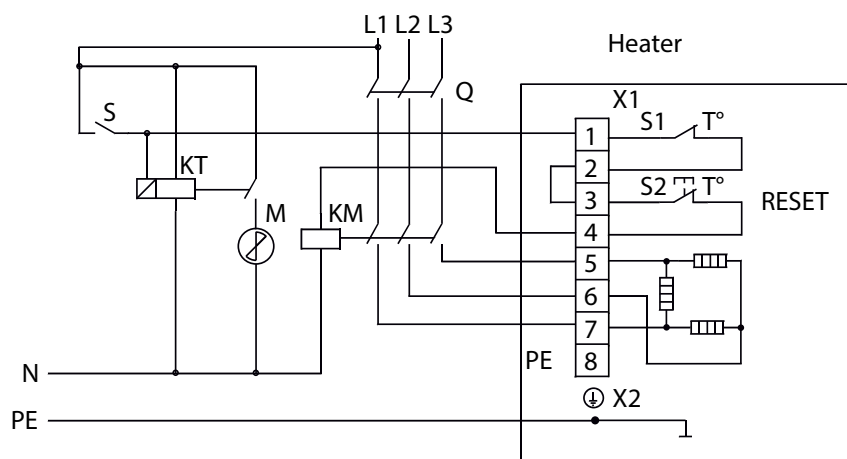

WIRING DIAGRAM OF THE RECTANGULAR HEATER WITH THREE ELECTRICAL HEATING ELEMENTS, THREE-PHASE POWER SUPPLY, STAR CONNECTION AND TIME-DELAY RELAY

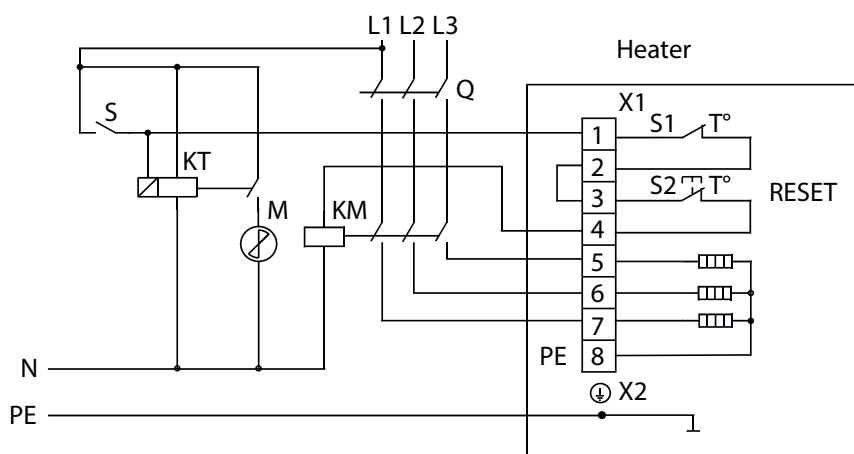

- S** – ON/OFF switch
- KT** – time-delay relay
- M** – fan
- KM** – magnetic starter
- Q** – automatic circuit breaker

Operation principle of the electric heater with control circuits is as follows:

As the ON/OFF switch **S** turns ON, the **KM** magnetic starter coil is charged through the closed contacts of the thermal switches. Consequently electric power is supplied to the heating elements through the closed contacts of the thermal switches and magnetic starter. Should at least one of the thermal switches turn on the power circuit of the magnetic starter **KM** and of the heating element gets broken thus preventing the heater overheating. The diagram shows the fan connection example with the time-delay relay **KT**. The motor **M** is turned off before the heater is turned off to ensure the electric heating elements cooling.

The automatic circuit breaker **Q** is designed for overload protection of the electrical circuits.

Wiring diagram types are determined by quantity of the heating elements, supply voltage characteristics, number of phases.

TECHNICAL MAINTENANCE



**DISCONNECT THE UNIT FROM POWER SUPPLY BEFORE ANY MAINTENANCE OPERATIONS!
MAKE SURE THE UNIT IS DISCONNECTED FROM POWER MAINS BEFORE REMOVING THE
PROTECTION.**

The heaters shall be operated and maintained by duly qualified experts.

Check the following conditions during the unit maintenance:

- Inspection of screw connections as well as rivet and welded joints;
- Inspection of tightening of ground screw clamps and electric connections;
- Inspection of the wire terminal connections;
- Cleaning of the electric heating elements of dust and dirt. Cleaning with any kinds of solvents and/or flammable substances is forbidden.

STORAGE AND TRANSPORTATION REGULATIONS

- Store the unit in the manufacturer's original packaging box in a dry closed ventilated premise with temperature range from +5 °C to +40 °C and relative humidity up to 70 %.
- Storage environment must not contain aggressive vapors and chemical mixtures provoking corrosion, insulation, and sealing deformation.
- Use suitable hoist machinery for handling and storage operations to prevent possible damage to the unit.
- Follow the handling requirements applicable for the particular type of cargo.
- The unit can be carried in the original packaging by any mode of transport provided proper protection against precipitation and mechanical damage. The unit must be transported only in the working position.
- Avoid sharp blows, scratches, or rough handling during loading and unloading.
- Prior to the initial power-up after transportation at low temperatures, allow the unit to warm up at operating temperature for at least 3-4 hours.

MANUFACTURER'S WARRANTY

The product is in compliance with EU norms and standards on low voltage guidelines and electromagnetic compatibility. We hereby declare that the product complies with the provisions of Electromagnetic Compatibility (EMC) Directive 2014/30/EU of the European Parliament and of the Council, Low Voltage Directive (LVD) 2014/35/EU of the European Parliament and of the Council and CE-marking Council Directive 93/68/EEC. This certificate is issued following test carried out on samples of the product referred to above.

The manufacturer hereby warrants normal operation of the unit for 24 months after the retail sale date provided the user's observance of the transportation, storage, installation, and operation regulations. Should any malfunctions occur in the course of the unit operation through the Manufacturer's fault during the guaranteed period of operation, the user is entitled to get all the faults eliminated by the manufacturer by means of warranty repair at the factory free of charge. The warranty repair includes work specific to elimination of faults in the unit operation to ensure its intended use by the user within the guaranteed period of operation. The faults are eliminated by means of replacement or repair of the unit components or a specific part of such unit component.

The warranty repair does not include:

- routine technical maintenance
- unit installation/dismantling
- unit setup

To benefit from warranty repair, the user must provide the unit, the user's manual with the purchase date stamp, and the payment paperwork certifying the purchase. The unit model must comply with the one stated in the user's manual. Contact the Seller for warranty service.

The manufacturer's warranty does not apply to the following cases:

- User's failure to submit the unit with the entire delivery package as stated in the user's manual including submission with missing component parts previously dismantled by the user.
- Mismatch of the unit model and the brand name with the information stated on the unit packaging and in the user's manual.
- User's failure to ensure timely technical maintenance of the unit.
- External damage to the unit casing (excluding external modifications as required for installation) and internal components caused by the user.
- Redesign or engineering changes to the unit.
- Replacement and use of any assemblies, parts and components not approved by the manufacturer.
- Unit misuse.
- Violation of the unit installation regulations by the user.
- Violation of the unit control regulations by the user.
- Unit connection to power mains with a voltage different from the one stated in the user's manual.
- Unit breakdown due to voltage surges in power mains.
- Discretionary repair of the unit by the user.
- Unit repair by any persons without the manufacturer's authorization.
- Expiration of the unit warranty period.
- Violation of the unit transportation regulations by the user.
- Violation of the unit storage regulations by the user.
- Wrongful actions against the unit committed by third parties.
- Unit breakdown due to circumstances of insuperable force (fire, flood, earthquake, war, hostilities of any kind, blockades).
- Missing seals if provided by the user's manual.
- Failure to submit the user's manual with the unit purchase date stamp.
- Missing payment paperwork certifying the unit purchase.



FOLLOWING THE REGULATIONS STIPULATED HEREIN WILL ENSURE A LONG AND TROUBLE-FREE OPERATION OF THE UNIT



USER'S WARRANTY CLAIMS SHALL BE SUBJECT TO REVIEW ONLY UPON PRESENTATION OF THE UNIT, THE PAYMENT DOCUMENT AND THE USER'S MANUAL WITH THE PURCHASE DATE STAMP

CERTIFICATE OF ACCEPTANCE

Unit Type	Duct electrical heater
Model	
Serial Number	
Manufacture Date	
Quality Inspector's Stamp	

SELLER INFORMATION

Seller	
Address	
Phone Number	
E-mail	
Purchase Date	
This is to certify acceptance of the complete unit delivery with the user's manual. The warranty terms are acknowledged and accepted.	
Customer's Signature	

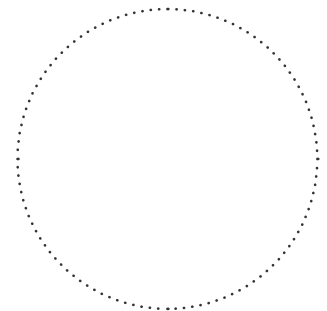

Seller's Stamp

INSTALLATION CERTIFICATE

The _____ unit is installed pursuant to the requirements stated in the present user's manual.	
Company name	
Address	
Phone Number	
Installation Technician's Full Name	
Installation Date:	Signature:
The unit has been installed in accordance with the provisions of all the applicable local and national construction, electrical and technical codes and standards. The unit operates normally as intended by the manufacturer.	
Signature:	

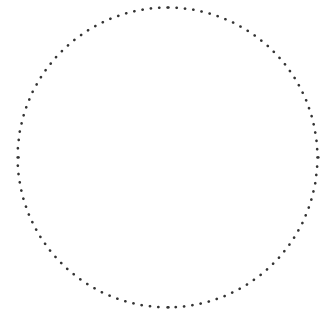

Installation Stamp

WARRANTY CARD

Unit Type	Duct electrical heater
Model	
Serial Number	
Manufacture Date	
Purchase Date	
Warranty Period	
Seller	

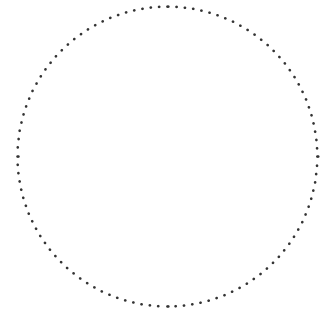

Seller's Stamp

