

SINGLE-BLOCK AIR SUPPLY UNIT



BLAUBOX EC ME 300 S30/31/32
BLAUBOX EC ME 400 S30/31/32
BLAUBOX EC ME 700 S30/31/32
BLAUBOX EC ME 1000 S30/31/32
BLAUBOX EC ME 1500 S30/31/32
BLAUBOX EC ME 2000 S30/31/32
BLAUBOX EC ME 3000 S30/31/32
BLAUBOX EC ME 4000 S30/31/32

EN

USER'S MANUAL

CONTENTS

Safety requirements.....	3
Purpose.....	5
Delivery set.....	5
Designation key.....	5
Technical data.....	6
Design and operating principle	9
Mounting and set-up.....	13
Connection to power mains	15
Technical maintenance.....	21
Troubleshooting.....	22
Storage and transportation regulations.....	22
Manufacturer's warranty.....	23
Certificate of acceptance.....	27
Seller information	27
Installation certificate.....	27
Warranty card.....	27

This user's manual is a main operating document intended for technical, maintenance, and operating staff.

The manual contains information about purpose, technical details, operating principle, design, and installation of the BLAUBOX EC ME 300/400/700/1000/1500/2000/3000/4000 S30/31/32 unit and all its modifications.

Technical and maintenance staff must have theoretical and practical training in the field of ventilation systems and should be able to work in accordance with workplace safety rules as well as construction norms and standards applicable in the territory of the country.

SAFETY REQUIREMENTS

This unit is not intended for use by persons (including children) with reduced physical, sensory or mental capabilities, or lack of experience and knowledge, unless they have been given supervision or instruction concerning use of the unit by a person responsible for their safety. Children should be supervised to ensure that they do not play with the unit.

This appliance can be used by children aged from 8 years and above and persons with reduced physical, sensory or mental capabilities or lack of experience and knowledge if they have been given supervision or instruction concerning use of the appliance in a safe way and understand the hazards involved.

Cleaning and user maintenance shall not be made by children without supervision.

Children shall not play with the appliance.

This appliance incorporates an earth connection for functional purposes.

Connection to the mains must be made through a disconnecting device, which is integrated into the fixed wiring system in accordance with the wiring rules for design of electrical units, and has a contact separation in all poles that allows for full disconnection under overvoltage category III conditions.

If the supply cord is damaged, it must be replaced by the manufacturer, its service agent, or similarly qualified persons in order to avoid a safety hazard.

CAUTION: In order to avoid a safety hazard due to inadvertent resetting of the thermal cut-out, this unit must not be supplied through an external switching device, such as a timer, or connected to a circuit that is regularly switched on and off by the utility.

Ensure that the unit is switched off from the supply mains before removing the guard.

WARNING: If there are any unusual oscillating movements, immediately stop using the unit and contact the manufacturer, its service agent or suitably qualified persons.

The replacement of parts of the safety suspension system device shall be performed by the manufacturer, its service agent or suitably qualified persons.

Precautions must be taken to avoid the back-flow of gases into the room from the open flue of gas or other fuel-burning appliances.

The appliance may adversely affect the safe operation of appliances burning gas or other fuels (including those in other rooms) due to back flow of combustion gases. These gases can potentially result in carbon monoxide poisoning. After installation of the unit the operation of flued gas appliances should be tested by a competent person to ensure that back flow of combustion gases does not occur.

All operations described in this manual must be performed by qualified personnel only, properly trained and qualified to install, make electrical connections and maintain ventilation units.

Do not attempt to install the product, connect it to the mains, or perform maintenance yourself. This is unsafe and impossible without special knowledge.

Disconnect the power supply prior to any operations with the unit.

All user's manual requirements as well as the provisions of all the applicable local and national construction, electrical, and technical norms and standards must be observed when installing and operating the unit.

Disconnect the unit from the power supply prior to any connection, servicing, maintenance, and repair operations.

Connection of the unit to power mains is allowed by a qualified electrician with a work permit for the electric units up to 1000 V after careful reading of the present user's manual.

Check the unit for any visible damage of the impeller, the casing, and the grille before starting installation. The casing internals must be free of any foreign objects that can damage the impeller blades.

While mounting the unit, avoid compression of the casing! Deformation of the casing may result in motor jam and excessive noise.

Misuse of the unit and any unauthorised modifications are not allowed.

Do not expose the unit to adverse atmospheric agents (rain, sun, etc.).

Transported air must not contain any dust or other solid impurities, sticky substances, or fibrous materials.

Do not use the unit in a hazardous or explosive environment containing spirits, gasoline, insecticides, etc.

Do not close or block the intake or extract vents in order to ensure the efficient air flow.

Do not sit on the unit and do not put objects on it.

The information in this user's manual was correct at the time of the document's preparation.

The Company reserves the right to modify the technical characteristics, design, or configuration of its products at any time in order to incorporate the latest technological developments.

Never touch the unit with wet or damp hands.

Never touch the unit when barefoot.

BEFORE INSTALLING ADDITIONAL EXTERNAL DEVICES, READ THE RELEVANT USER MANUALS.



**THE PRODUCT MUST BE DISPOSED SEPARATELY AT THE END OF ITS SERVICE LIFE.
DO NOT DISPOSE THE UNIT AS UNSORTED DOMESTIC WASTE.**

PURPOSE

The unit is intended for filtering, supplying and heating purified intake air in offices, hotels, cafés, conference halls, manufacturing facilities, retail establishments and other residential and public spaces.

The unit is a component part and is not designed for stand-alone operation.

Transported air must not contain any flammable or explosive mixtures, evaporation of chemicals, sticky substances, fibrous materials, coarse dust, soot and oil particles or environments favourable for the formation of hazardous substances (toxic substances, dust, pathogenic germs).

The unit must not be used for purposes other than those specified in this manual or outside the ambient conditions specified herein. The unit is rated for continuous operation.

DELIVERY SET

Name	BLAUBOX EC ME 300/400/700/1000/1500/2000/3000/4000 S31	BLAUBOX EC ME 300/400/700/1000/1500/2000/3000/4000 S30/32
BLAUBOX unit	1 pc.	1 pc.
Remote controller	–	1 pc.
Outdoor temperature sensor	1 pc.	1 pc.
User's manual	1 pc.	1 pc.
Packing box	1 pc.	1 pc.

DESIGNATION KEY

BLAUBOX EC ME 1000 -15 L S31

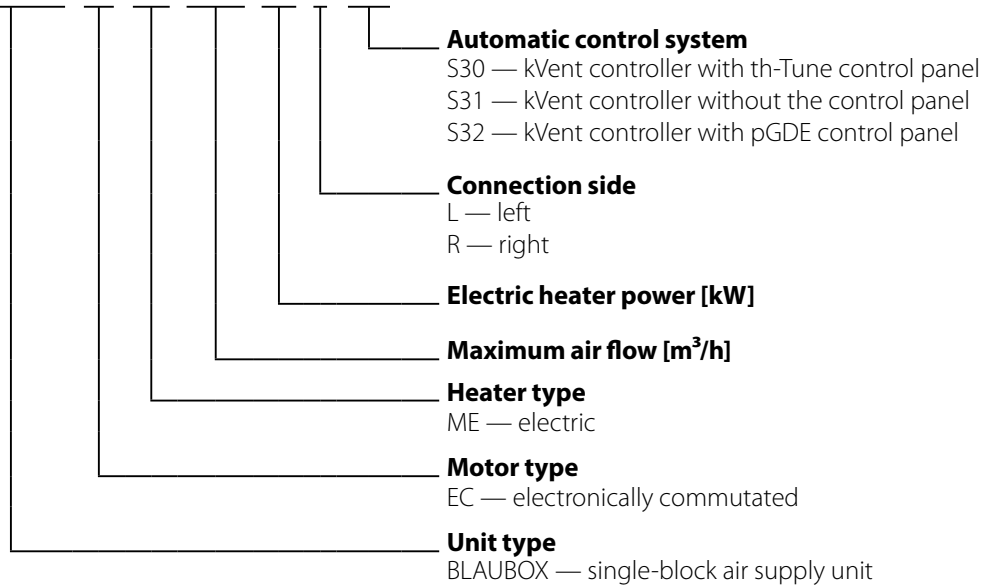

TECHNICAL DATA

The unit is designed for indoor application with the ambient temperature ranging from +1 °C up to +40 °C and relative humidity up to 80 % without condensation. The transported air temperature should be from -30 °C to +40 °C with a relative humidity no more than 90%.

The unit is rated as a class I electric appliance.

Hazardous parts access and water ingress protection rating:

- IP22 for the unit connected to the air ducts
- IP44 for the unit motors

The unit design is constantly being improved, thus some models may be slightly different from those described in this manual.

**Overall and connection dimensions of the models
BLAUBOX EC ME 300 S30/31/32, BLAUBOX EC ME 400 S30/31/32, BLAUBOX EC ME 700 S30/31/32**

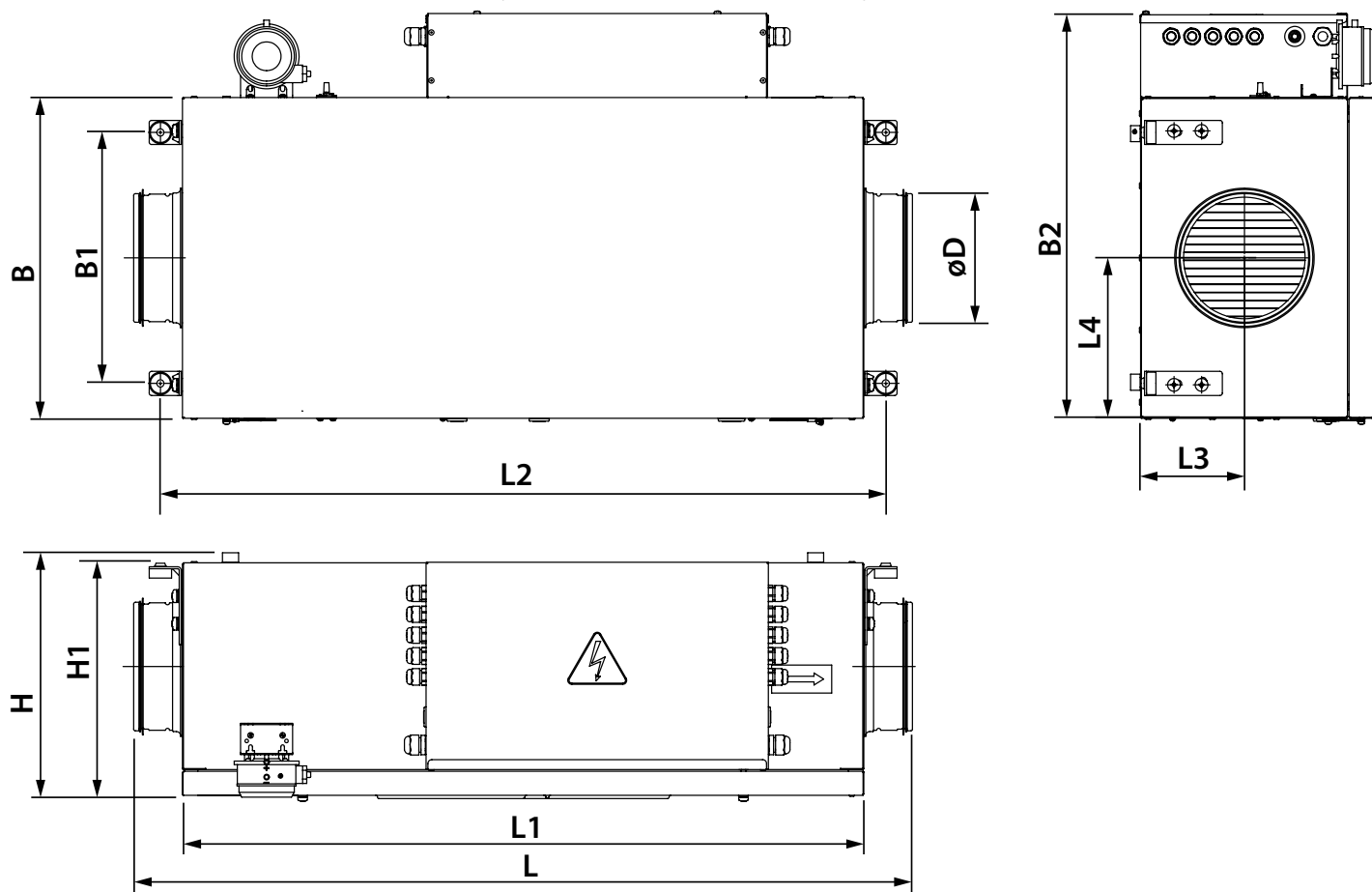

Model	L	L1	L2	L3	L4	H	H1	B	B1	B2	øD
BLAUBOX EC ME 300 S30/31/32	950	850	903	129	200	310	290	400	313	514	160
BLAUBOX EC ME 400 S30/31/32	972	850	903	160	200	370	351	400	313	514	200
BLAUBOX EC ME 700 S30/31/32	972	850	903	160	225	370	351	460	353	565	250

**Overall and connection dimensions of the models
BLAUBOX EC ME 1000 S30/31/32, BLAUBOX EC ME 1500 S30/31/32, BLAUBOX EC ME 2000 S30/31/32,
BLAUBOX EC ME 3000 S30/31/32, BLAUBOX EC ME 4000 S30/31/32 (without side panels)**

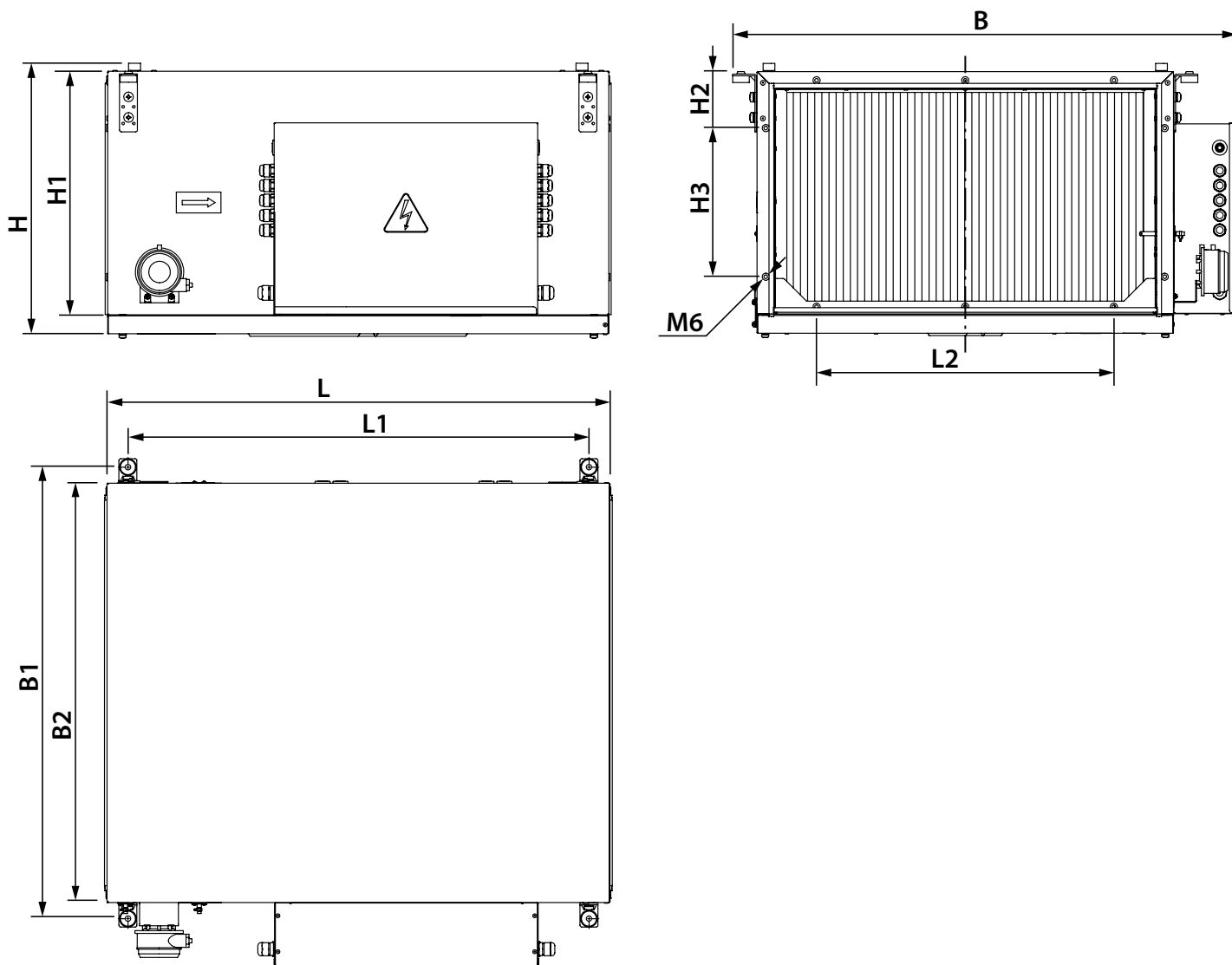

Model	L	L1	L2	H	H1	H2	H3	B	B1	B2
BLAUBOX EC ME 1000 S30/31/32	840	770	500	393	348	95	160	746	653	600
BLAUBOX EC ME 1500 S30/31/32	840	770	500	453	408	95	250	847	754	700
BLAUBOX EC ME 2000 S30/31/32	840	770	500	453	408	95	250	847	754	700
BLAUBOX EC ME 3000 S30/31/32	1140	1070	600	513	468	95	310	944	853	800
BLAUBOX EC ME 4000 S30/31/32	1140	1070	600	563	518	95	360	1087	993	940

**Overall and connection dimensions of the models
 BLAUBOX EC ME 1000 S30/31/32, BLAUBOX EC ME 1500 S30/31/32, BLAUBOX EC ME 2000 S30/31/32,
 BLAUBOX EC ME 3000 S30/31/32, BLAUBOX EC ME 4000 S30/31/32 (with side panels)**

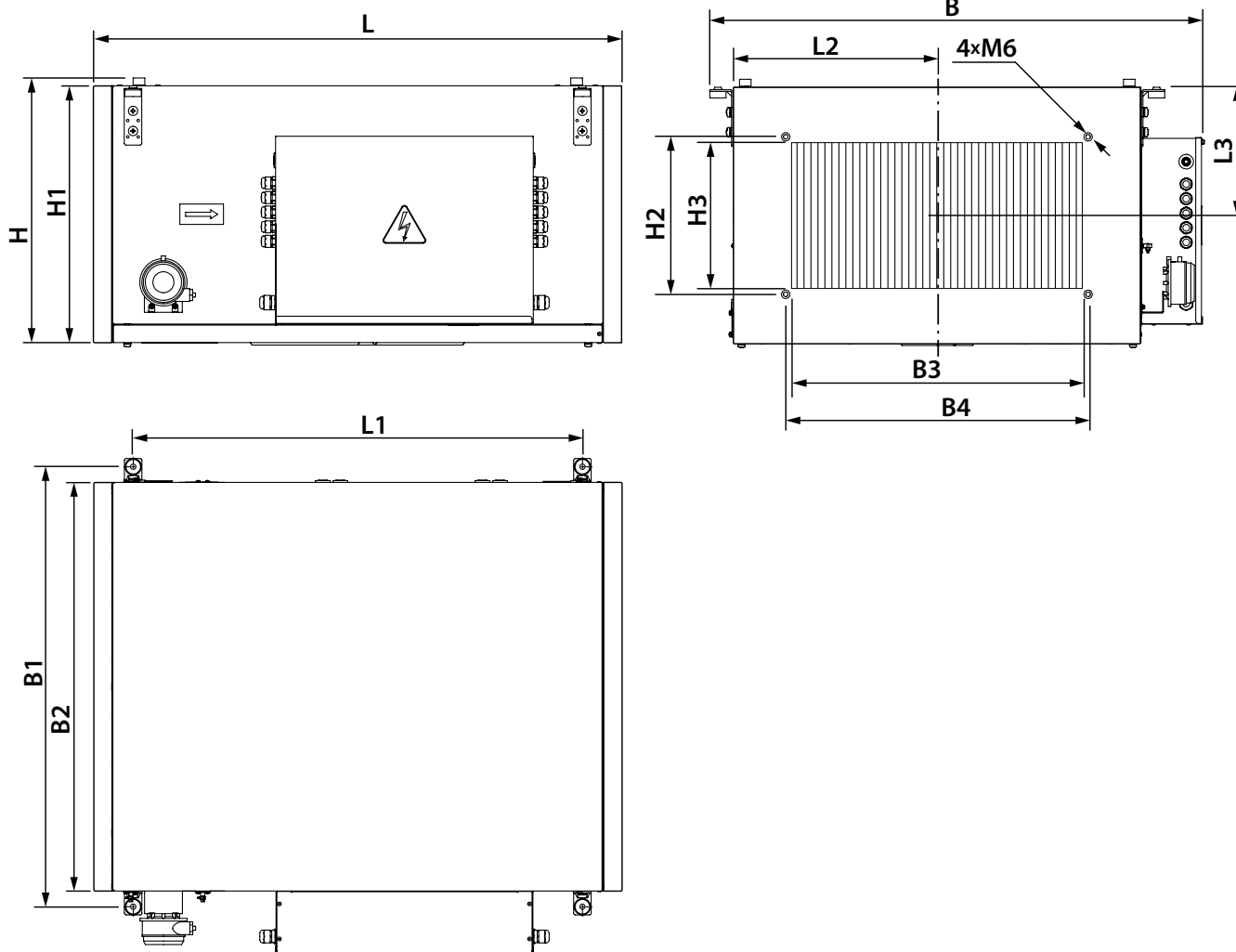

Model	L	L1	L2	L3	H	H1	H2	H3	B	B1	B2	B3	B4
BLAUBOX EC ME 1000 S30/31/32	900	770	300	190	393	380	220	200	746	653	600	400	420
BLAUBOX EC ME 1500 S30/31/32	900	770	350	220	453	440	270	250	847	754	700	500	520
BLAUBOX EC ME 2000 S30/31/32	900	770	350	220	453	440	320	300	847	754	700	500	520
BLAUBOX EC ME 3000 S30/31/32	1200	1070	400	250	513	500	320	300	944	853	800	600	620
BLAUBOX EC ME 4000 S30/31/32	1200	1070	470	275	563	550	420	400	1087	993	940	700	720



DESIGN AND OPERATING PRINCIPLE

The unit is housed in a sound-insulated galvanized steel casing (item 1). The unit casing has 4 mounting brackets with anti-vibration connectors for ceiling or wall mounting (item 5).

The air flow direction is indicated by the arrow on the fan casing.

The bottom side of the casing is covered with a removable cover (item 2), which is secured with 4 screws (item 4).

A control unit (item 3) is installed on the casing. The power and control cables are pulled through cable glands (item 6). In addition, a pressure drop relay can be mounted on the unit body, which is activated when the pressure drop across the filter increases (pos. 8).

Models BLAUBOX EC ME 1000 S30/31/32, BLAUBOX EC ME 1500 S30/31/32, BLAUBOX EC ME 2000 S30/31/32, BLAUBOX EC ME 3000 S30/31/32, BLAUBOX EC ME 4000 S30/31/32 are equipped with end panels (item 7) for connecting the unit to the air duct via flexible inserts.

To install the unit directly into a rectangular air duct, the end panels must be removed.

For ease of electrical connection, the units can be ordered with the control unit located either on right or left side of the casing (right- and left-side versions, respectively, as indicated in the «Designation key» section).

If necessary, the control unit can be moved to the other side of the unit casing before being installed in the ventilation system.

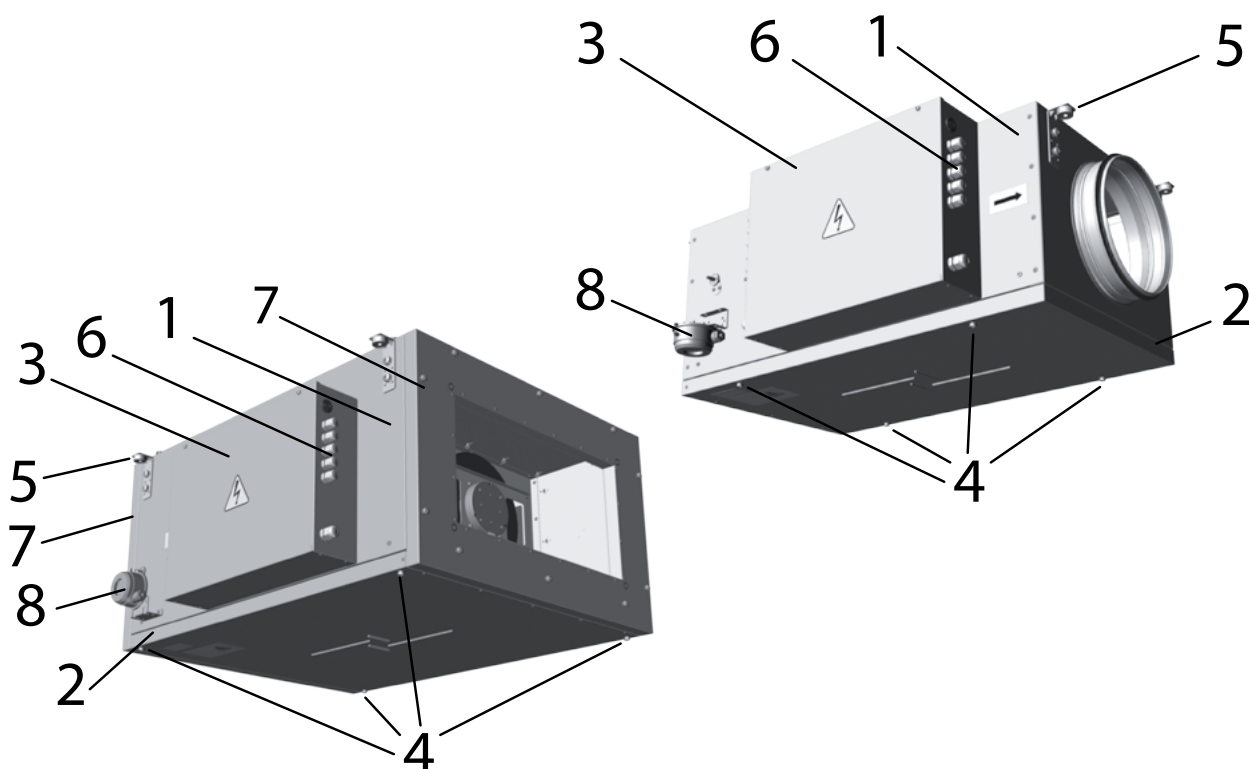

TOP VIEW

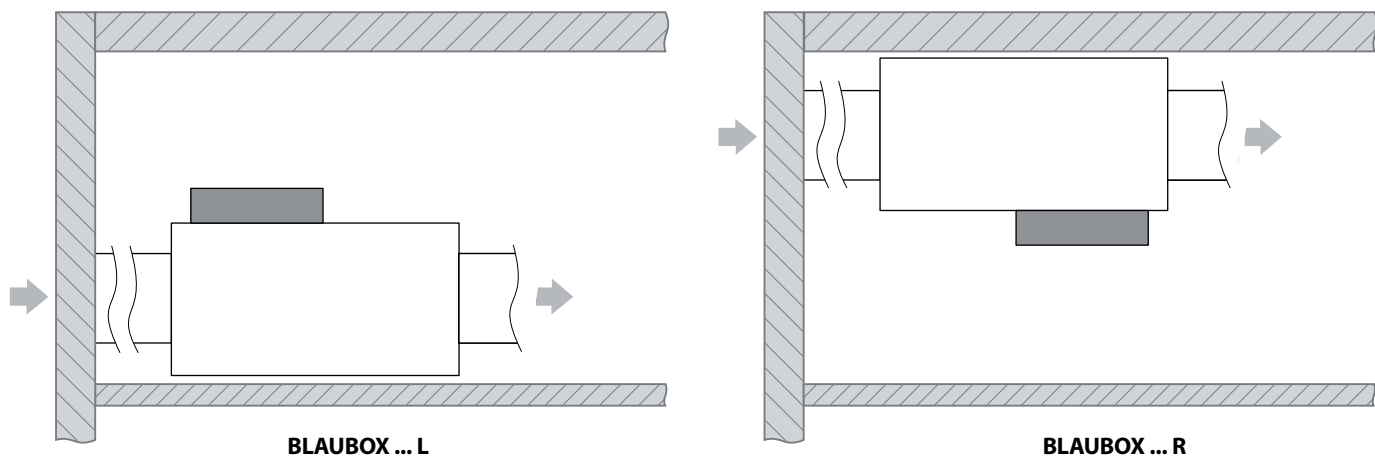

The figure below shows the internals of the left and right version of the units with the removable cover removed. The air flow direction is indicated by the arrows.

- The inlet and outlet spigots for duct connections (item 1 and 2 respectively);
- air filter with G4 filtration class (item 3);
- block of triacs on the cooling radiator (item 4);
- block of heaters (item 5);
- bracket with two thermostats mounted on it with low threshold and automatic return (item 6) and with high threshold and manual return (item 7);
- fan unit (item 8).

BOTTOM VIEW

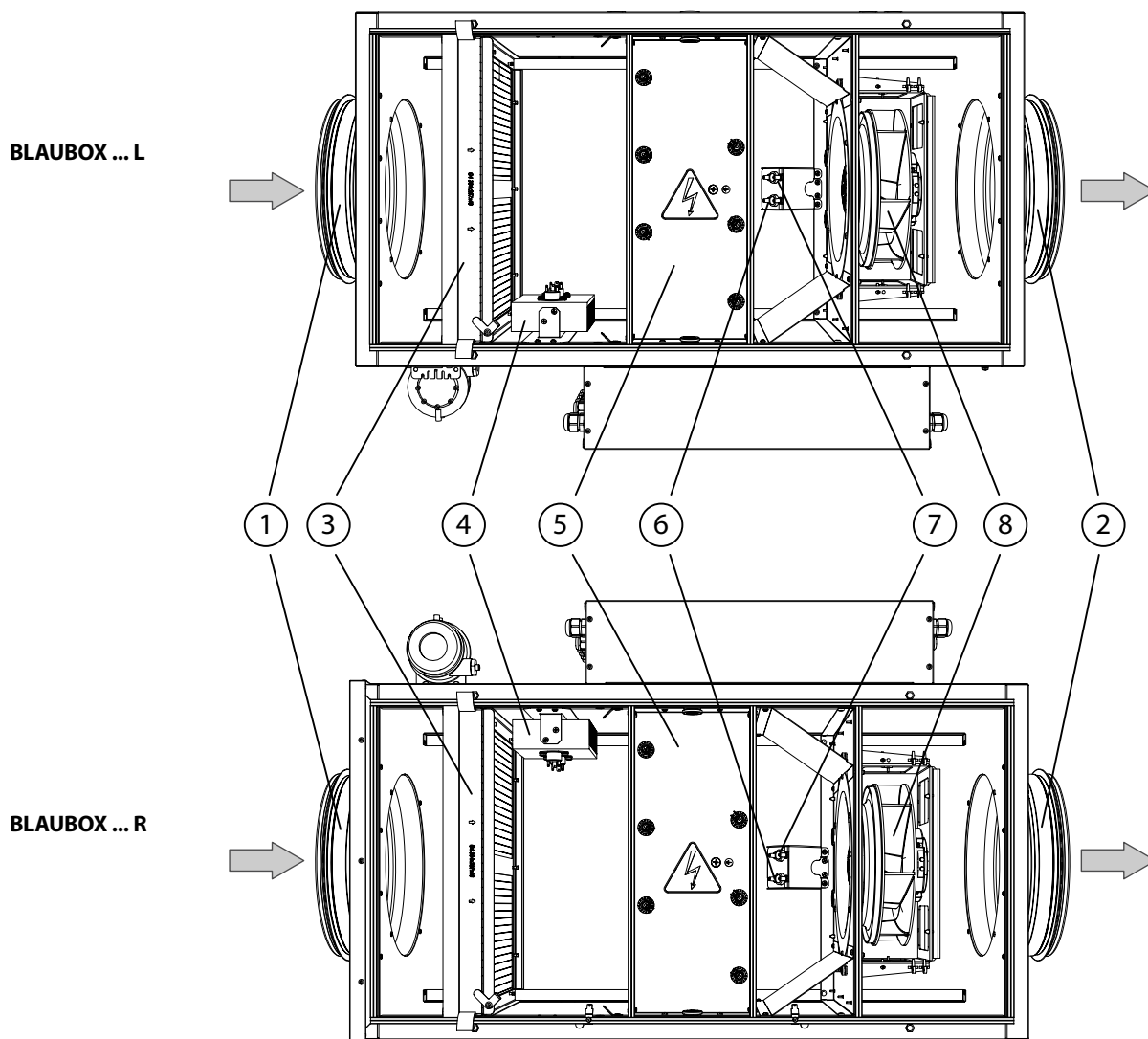

BOTTOM VIEW

BLAUBOX ... L

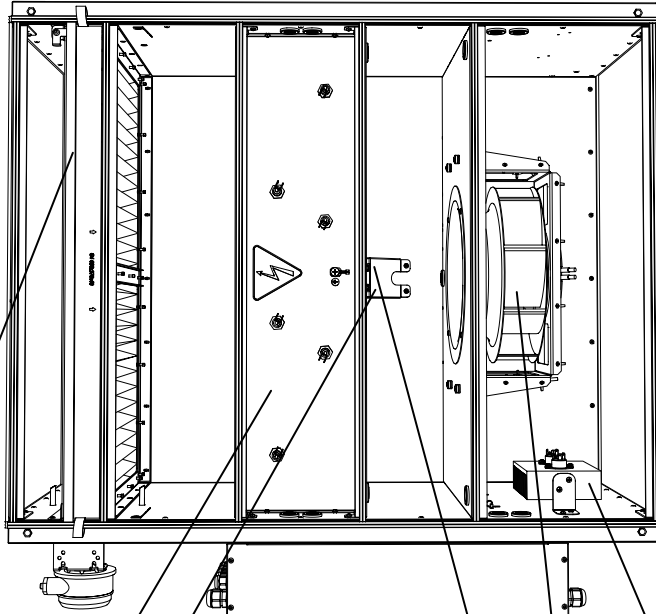

3

5

6

7

8

4

BLAUBOX ... R

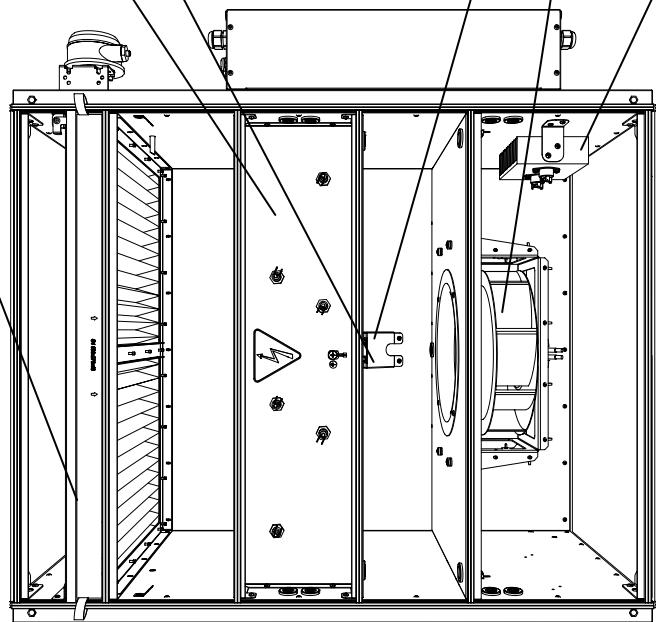

The unit supplies heated and filtered outdoor air into the room.

The unit uses a frameless centrifugal fan directly driven by an external rotor motor. The fan impeller blades are curved backwards. The motor has built-in thermal protection and requires no maintenance.

After filtration, the air passes through the block of heaters. The unit automation regulates the power of the heaters in such a manner so as to maintain the set air temperature at the unit outlet.

The electric heater has double overheating protection.

In case a thermostat with low threshold and automatic return is activated, the heater is turned off and the fan continues to operate, the air is blown through the unit for a set time, after which the unit is turned off. After the thermostat returns to its initial position, the unit turns on and continues to operate with the settings active prior to activation of the thermostat. Automatic turn on of the unit is possible three times in a row within one hour. In case this thermostat activates for the fourth time, the unit will not turn on.

In case a thermostat with high threshold and manual return is activated, the heater is turned off and the unit continues to operate without being able to turn on the heater. To return the heater to operation, press the manual reset button on the thermostat.

WARNING! Manual restart of the unit after a high threshold thermostat has tripped must be performed by a qualified technician after the causes of overheating have been eliminated.

WARNING! The air flow speed must be at least 1.5 m/s.

MOUNTING AND SET-UP



WHILE INSTALLING THE UNIT ENSURE CONVENIENT ACCESS FOR SUBSEQUENT MAINTENANCE AND REPAIR

The units are installed between the ducts, taking into account the direction of air flow, which is indicated by an arrow on the casing. Units BLAUBOX EC ME 300 S30/31/32, BLAUBOX EC ME 400 S30/31/32, BLAUBOX EC ME 700 S30/31/32 have spigots for connecting to air ducts with round cross-section.

Units BLAUBOX EC ME 1000 S30/31/32, BLAUBOX EC ME 1500 S30/31/32, BLAUBOX EC ME 2000 S30/31/32, BLAUBOX EC ME 3000 S30/31/32, BLAUBOX EC ME 4000 S30/31/32 are installed in a rectangular air duct system through flexible inserts.

For direct installation of units BLAUBOX EC ME 1000 S30/31/32, BLAUBOX EC ME 1500 S30/31/32, BLAUBOX EC ME 2000 S30/31/32, BLAUBOX EC ME 3000 S30/31/32, BLAUBOX EC ME 4000 S30/31/32 in a rectangular air duct system, the end panels must be removed.

WARNING!

- To reduce aerodynamic losses related to air flow turbulence, use shaped reducers in order to reduce or increase the cross-section of air ducts.
- To minimise turbulence-induced air pressure losses, connect the straight air duct sections on both sides of the unit. Minimum straight air duct length: equal to 1 air duct diameter on intake side and 3 air duct diameters on outlet side
- It is necessary to protect the internal parts of the unit from penetration of foreign objects. For example, install a grill with a cell side size of no more than 12.5 mm to prevent free access to the fan and foreign objects from entering the unit.
- It is recommended to connect the duct through a flexible connection to reduce noise and vibration transmission. Such connections allow compensating for possible mounting inaccuracies when connecting the unit to air ducts.
- The equipment and air ducts that are to be connected must have their own mounting bracket in order to avoid transferring their own weight loads to the unit.

The unit must be mounted so that it can be accessed for service purposes. Enough space must be provided for the cover to open all the way. After removing the screws, the cover will hang on special cables.

Installation is possible on the ceiling or on the wall in such a way that the air flow is horizontal. In this case, the control unit can be located both above and below.

The mounting is carried out at 4 points with mounting brackets. It is recommended to use anchor threaded rods with nuts for fastening the unit. The vibration mounts on the unit casing must fit snugly against the ceiling or wall surface.

Fasteners for the unit mounting are not included into delivery set and should be ordered separately. While choosing fasteners consider the material of the mounting surface and the unit weight. For selection of the fasteners for unit mounting please refer to a service technician.

Install the outdoor temperature sensor in the air duct downstream of the unit along the air flow.

the units are available in the right- or left-side versions depending on the location of the control unit relative to the air flow direction. The unit is designed so that the control unit can be moved to the opposite side of the casing. This allows for a more rational placement of the equipment when installing the ventilation system.

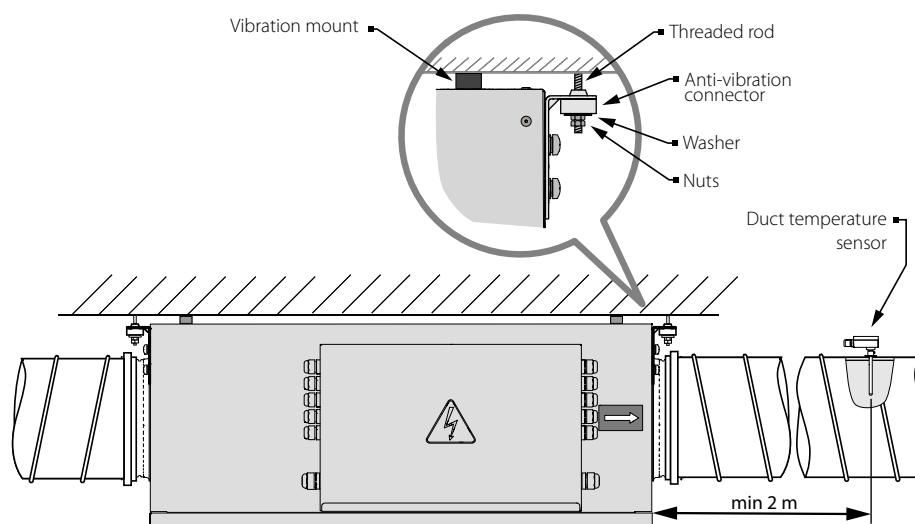

Moving the control unit to the opposite side of the casing

If you want to move the control unit before connecting the unit to the power supply and external devices, perform the below steps in the following order:

1. Position the unit on the surface by placing it on the vibration mounts with the removable cover upward. Remove the control box cover as shown in the figure below.
2. Remove the removable cover from the unit casing. To do this, remove the 4 screws that secure the cover and the screws that secure the safety cables to the unit casing as shown in the figure below.

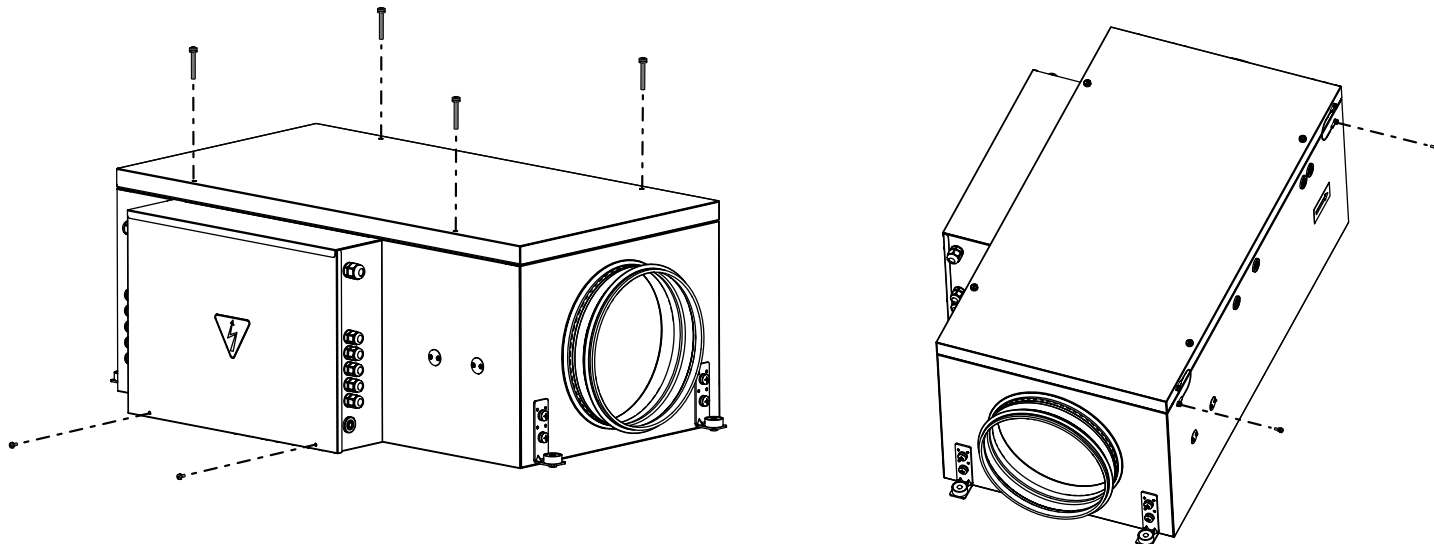

3. Label the wires connected to all devices in the control unit. Remember, photograph or write down the connection points of all cables.
4. Disconnect all cables and pull them out through cable glands inside the unit casing. Route all cables to the other side of the unit casing and run them through the cable glands on the opposite side. Secure the cables in the new position with cable ties.
5. Move the triac assembly on the cooling radiator (item 4 in the figure in the «Design and operating principles» section) together with the mounting bracket to the opposite side of the unit casing.
6. Remove the screws that secure the chassis with the automation elements in the control unit (highlighted in gray in the figure below). Then remove the screws that secure the control unit cover. The screws are indicated with arrows in the figure below. Install the control unit and chassis on the other side of the casing in reverse order using the same screws.

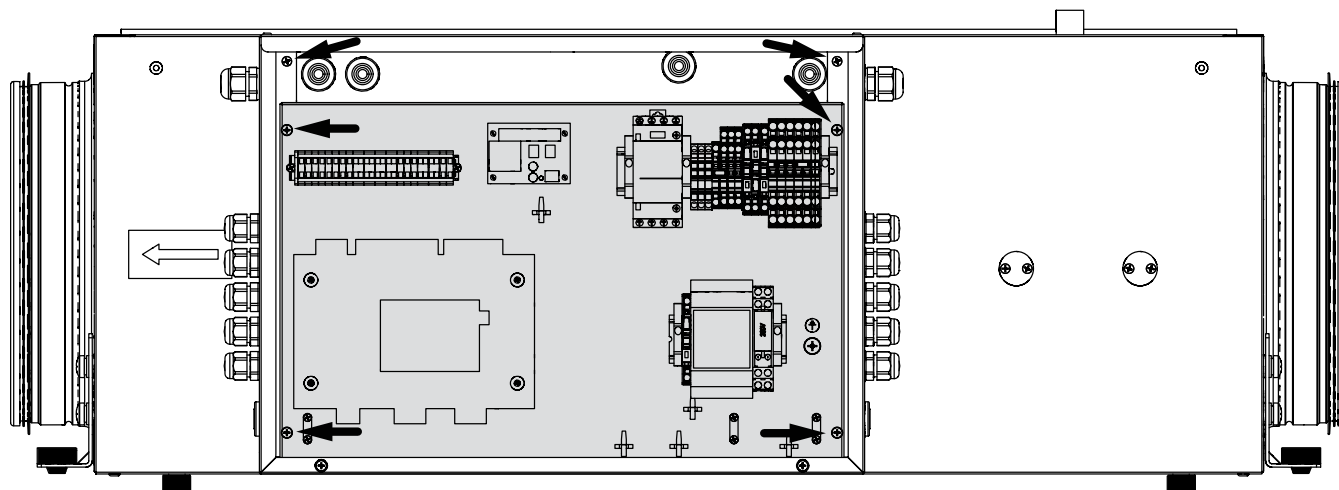

7. Connect all cables inside the unit in the new location at the same points as before disassembly. Reinstall the control unit cover.
8. Reinstall the removable cover of the unit casing. The cover can be rotated and secured so that it hangs on the safety cables on the convenient side during maintenance work on the unit. Threaded holes are provided on both sides for attaching the cables to the casing.

CONNECTION TO POWER MAINS

The connection must be made using durable, insulated and heat-resistant conductors (cables, wires).

The external power input must be equipped with an automatic circuit breaker built into the stationary wiring to open the circuit in the event of overload or short-circuit.

The position of the external circuit breaker must ensure free access for quick unit power-off.

The trip current of the automatic circuit breaker must exceed the maximum current consumption of the unit (refer to the «Technical data» section or to the unit label). It is recommended to select the rated current of the circuit breaker from the standard series, following the maximum current of the connected unit.

The circuit breaker is not included in the delivery set.

Below is a complete list of ventilation unit models and electric power supply system parameters.

WARNING! When using the CCU for the installations listed below, the CCU can only be used for cooling.

BLAUBOX EC ME 3000-45kW S31, BLAUBOX EC ME 4000-45kW S31, BLAUBOX EC ME 4000-54kW S31.

Model	Parameters of the electric power supply system
BLAUBOX EC ME 300-1.7 S30/31/32	1~230 V, 50 Hz
BLAUBOX EC ME 300-5.1 S30/31/32	3~400 V, 50 Hz
BLAUBOX EC ME 400-2.4 S30/31/32	1~230 V, 50 Hz
BLAUBOX EC ME 400-3.3 S30/31/32	3~400 V, 50 Hz
BLAUBOX EC ME 400-6.0 S30/31/32	3~400 V, 50 Hz
BLAUBOX EC ME 700-3.0 S30/31/32	3~400 V, 50 Hz
BLAUBOX EC ME 700-6.0 S30/31/32	3~400 V, 50 Hz
BLAUBOX EC ME 700-9.0 S30/31/32	3~400 V, 50 Hz
BLAUBOX EC ME 1000-6.0 S30/31/32	3~400 V, 50 Hz
BLAUBOX EC ME 1000-12.0 S30/31/32	3~400 V, 50 Hz
BLAUBOX EC ME 1000-15.0 S30/31/32	3~400 V, 50 Hz
BLAUBOX EC ME 1500-9.0 S30/31/32	3~400 V, 50 Hz
BLAUBOX EC ME 1500-15.0 S30/31/32	3~400 V, 50 Hz
BLAUBOX EC ME 1500-18.0 S30/31/32	3~400 V, 50 Hz
BLAUBOX EC ME 2000-12.0 S30/31/32	3~400 V, 50 Hz
BLAUBOX EC ME 2000-18.0 S30/31/32	3~400 V, 50 Hz
BLAUBOX EC ME 2000-24.0 S30/31/32	3~400 V, 50 Hz
BLAUBOX EC ME 3000-18.0 S30/31/32	3~400 V, 50 Hz
BLAUBOX EC ME 3000-27.0 S30/31/32	3~400 V, 50 Hz
BLAUBOX EC ME 3000-45.0 S30/31/32	3~400 V, 50 Hz
BLAUBOX EC ME 4000-24.0 S30/31/32	3~400 V, 50 Hz
BLAUBOX EC ME 4000-45.0 S30/31/32	3~400 V, 50 Hz
BLAUBOX EC ME 4000-54.0 S30/31/32	3~400 V, 50 Hz

When selecting wires cross-section, it is necessary to take into account the maximum permissible load current and the wire heating temperature, which depends on the type of its insulation, length and method of routing.

To connect the power supply and external devices, unscrew the two screws on the cover of the control unit and remove the cover, as shown in the figure in the «Mounting and set-up» section.

Lead the power supply cable and the cables for connecting the control panel and the outdoor temperature sensor through the cable glands in the control unit and connect them according to the wiring diagram.

WARNING! To ensure correct operation of the unit's controls, the outdoor temperature sensor must be installed in the supply air duct downstream of the unit along the air flow.

The sensor is provided in the delivery set and must be connected by the user according to the external connection diagram. Wiring diagrams for power supply and external devices are shown in the figure below.

BLAUBOX EC ME 300-1.7, BLAUBOX EC ME 400-2.4

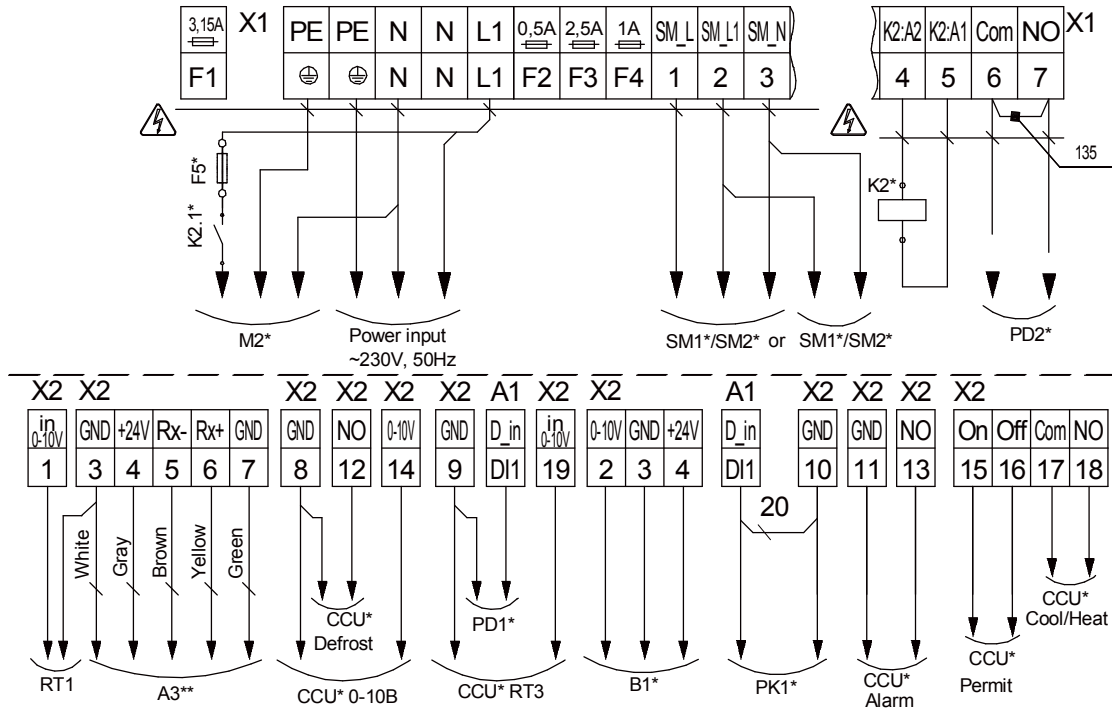

BLAUBOX EC ME 300-5.1, BLAUBOX EC ME 400-3.3, BLAUBOX EC ME 400-6.0, BLAUBOX EC ME 1000-15.0, BLAUBOX EC ME 1500-15.0, BLAUBOX EC ME 1500-18.0, BLAUBOX EC ME 2000-18.0

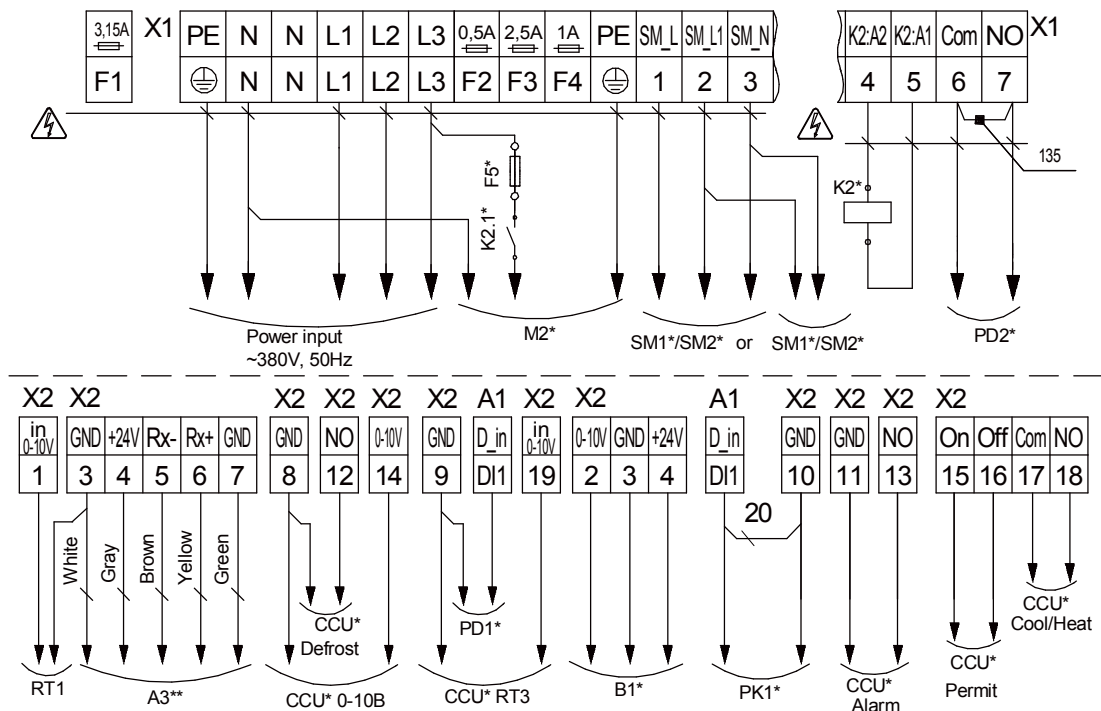

**BLAUBOX EC ME 700-3.0, BLAUBOX EC ME 700-6.0 EC, BLAUBOX EC ME 700 E-9.0,
BLAUBOX EC ME 1000-6.0, BLAUBOX EC ME 1000-12.0, BLAUBOX EC ME 1500-9.0, BLAUBOX EC ME 2000-12.0**

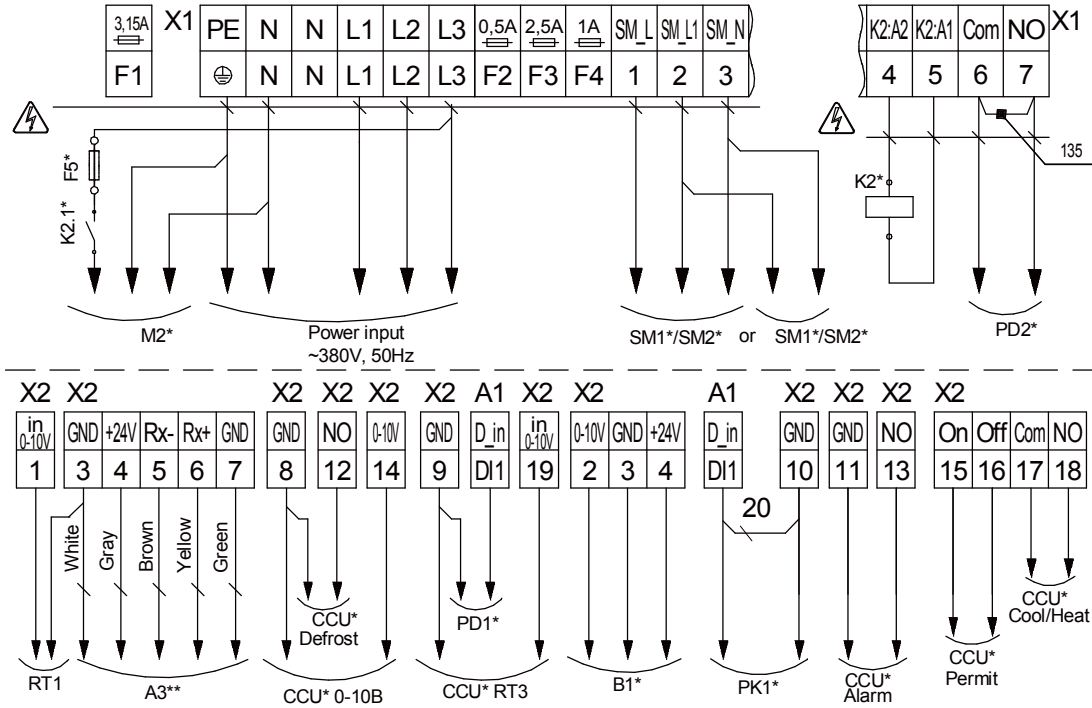

BLAUBOX EC ME 3000-18.0

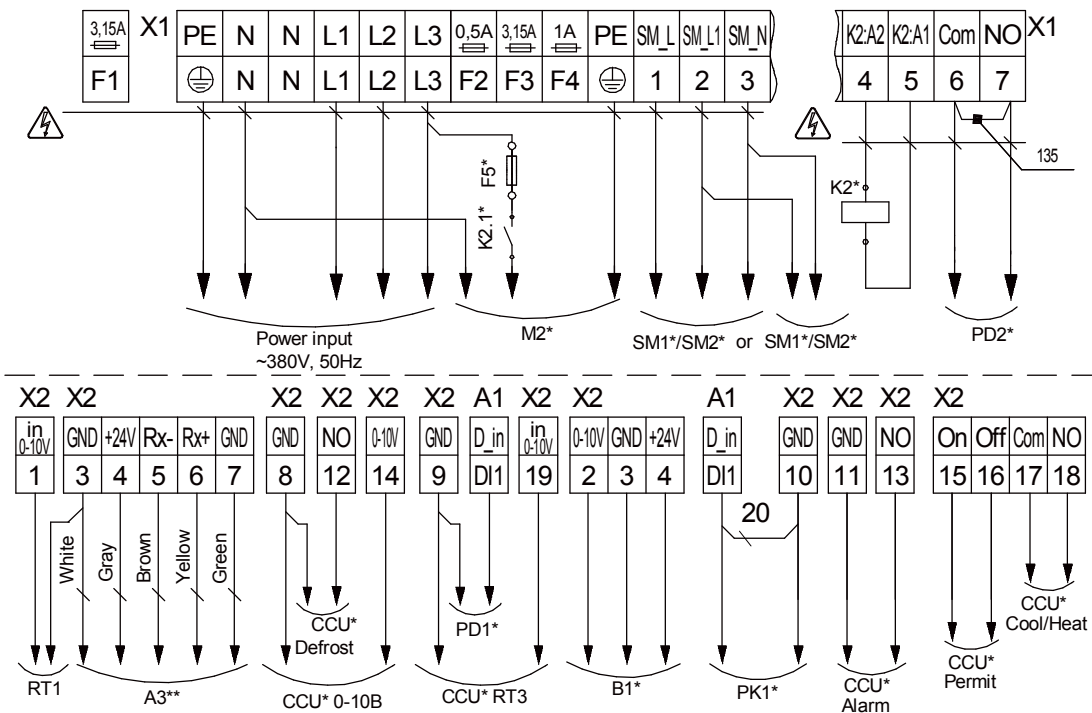

BLAUBOX EC ME 2000-24.0

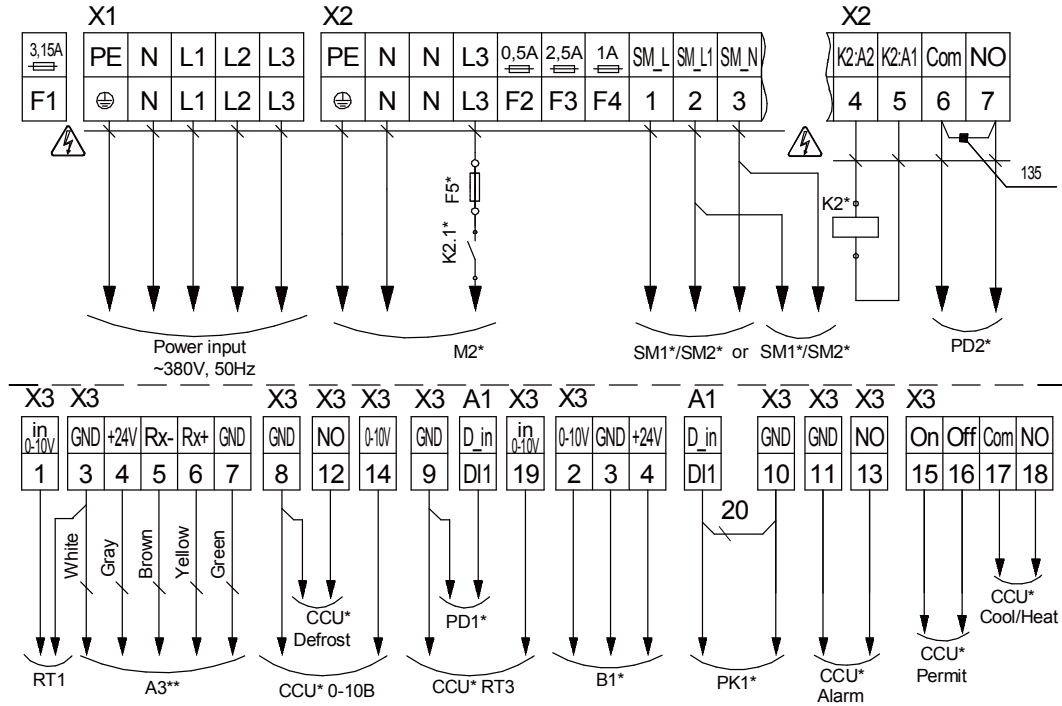

BLAUBOX EC ME 3000-27.0

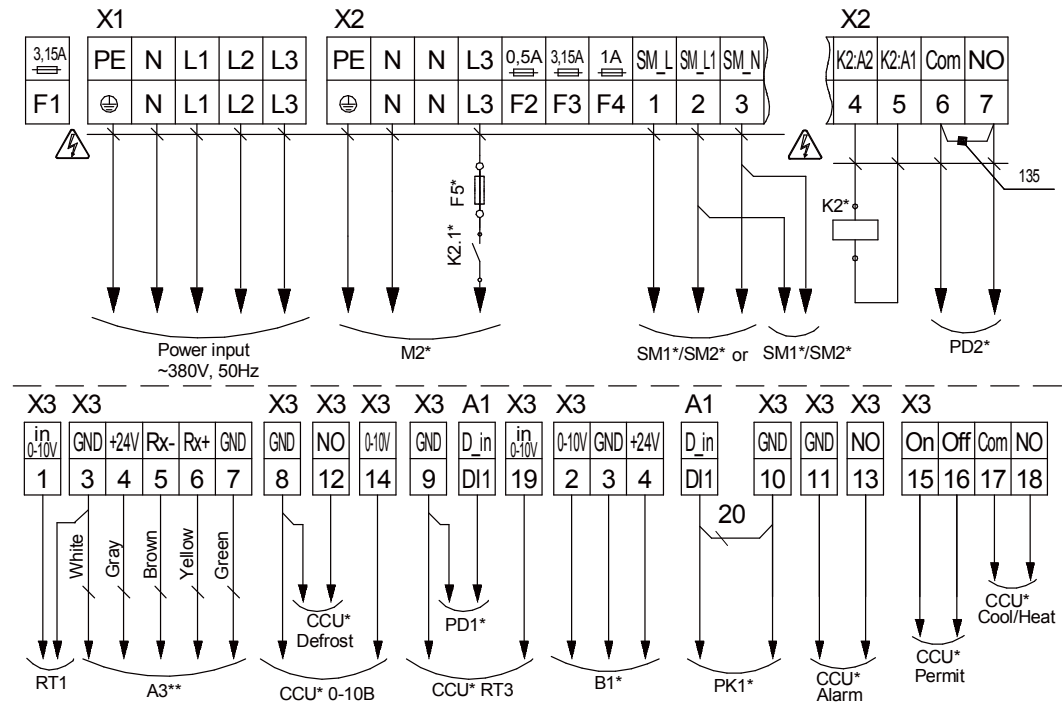

BLAUBOX EC ME 4000-24.0

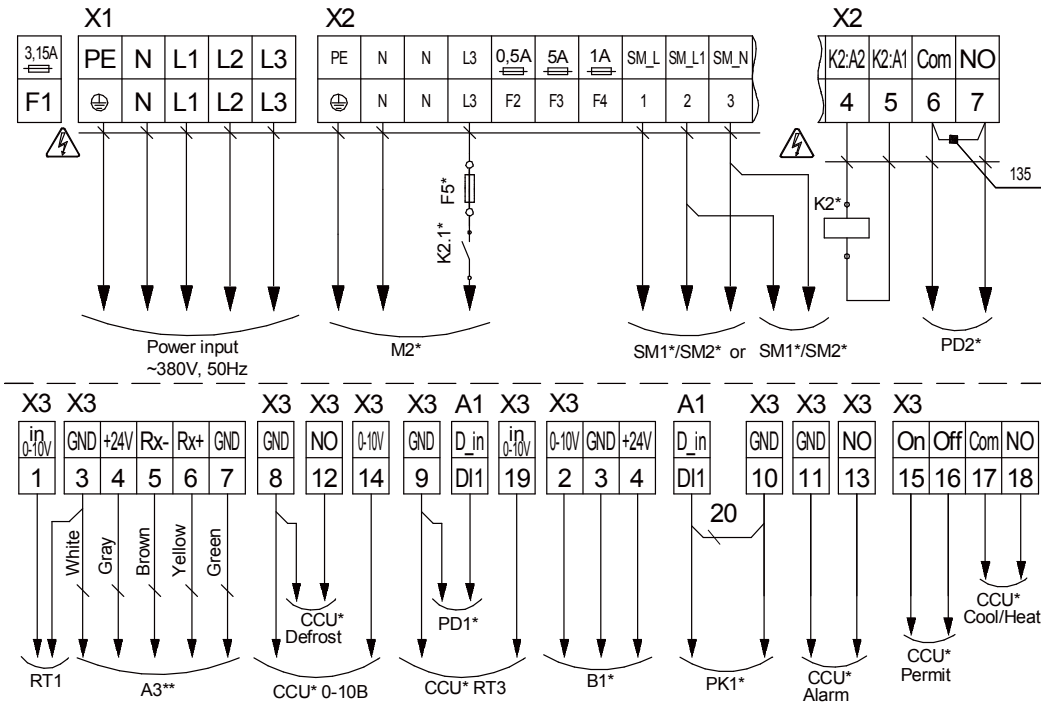

BLAUBOX EC ME 3000-45.0

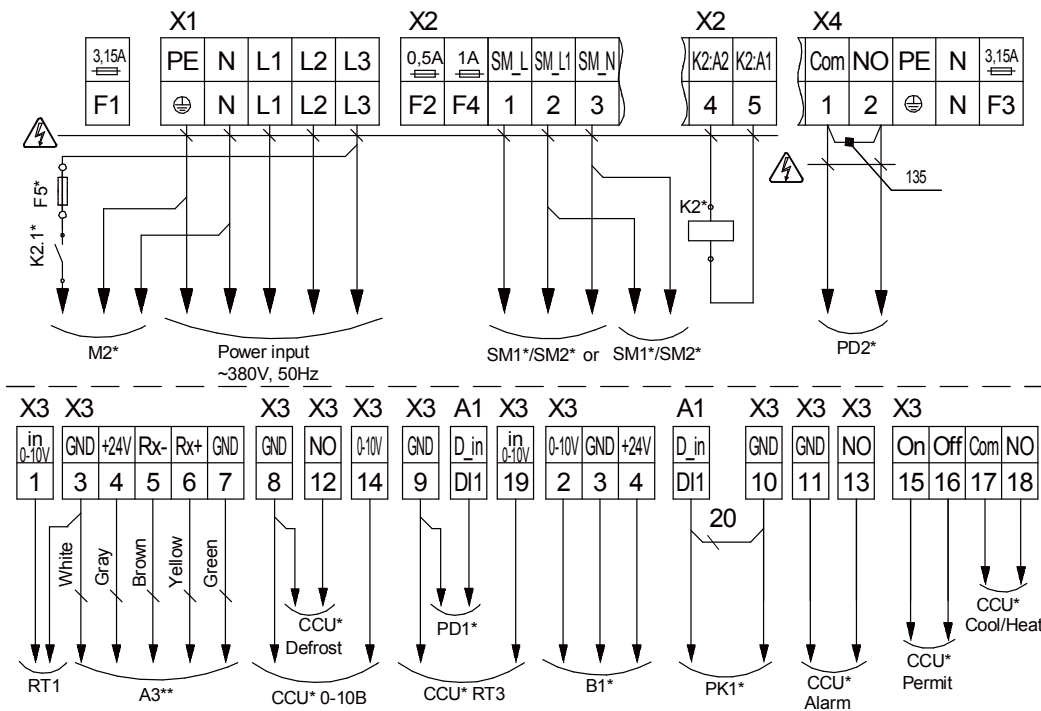

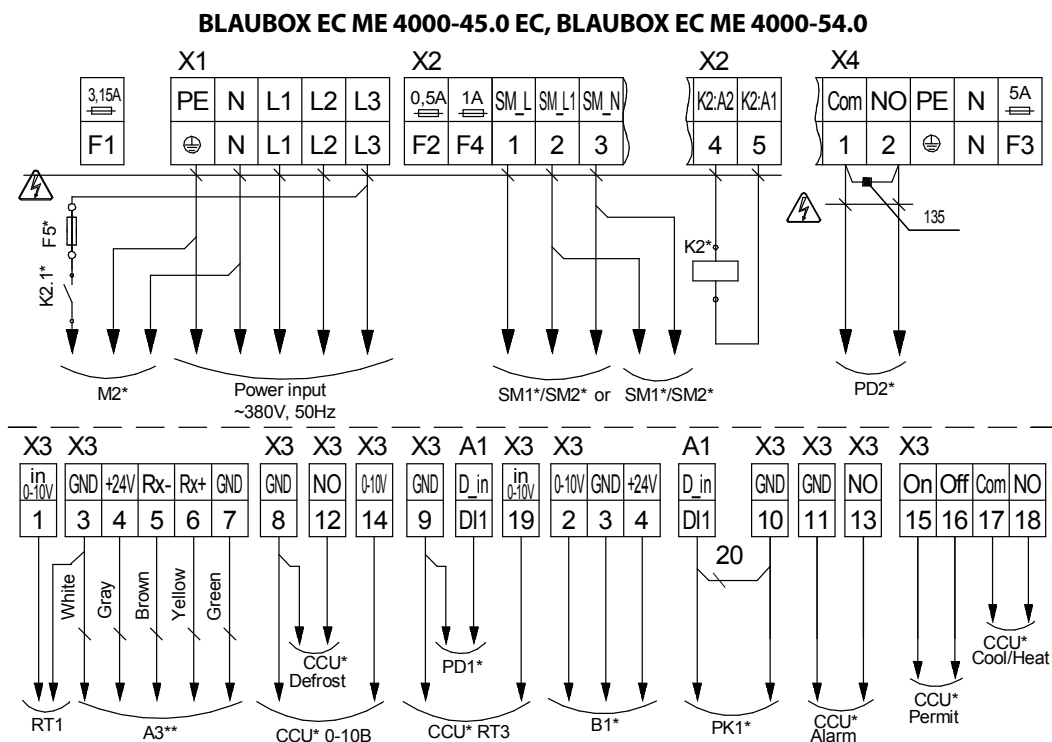

The interpretation of the designations and the characteristics of the connection cables are given in the table.

Designation	Name	Wire type	Type	Note
A3**	Control panel ThTune	5x0.25 mm ²		ThTune
B1*	CO ₂ sensor or humidity sensor RH1	3x0.25 mm ²		
CCU*	Control CCU temperature sensor	2x0.75 mm ²	NO	
CCU* RT3	Temperature sensor after the electric heater	2x0.25 mm ²		
F5*	Extractor fan fuse			Depending on M2
K2*	Relay for turning on the exhaust fan	2x0.5 mm ²	NO	For connection M2
M2*	Exhaust fan	2x0.75 mm ²		On/Off
PD1*	Differential pressure sensor for the filter	2x0.25 mm ²	NO	
PD2*	Differential pressure sensor	2x0.25 mm ²	NO	Remove the jumper 135
PK1*	Fire Alarm	2x0.5 mm ²	NC	Remove the jumper 20
SM1*	Air damper drive 3 position	3x0.5 mm ²		
SM1*	Air damper drive 2 position	2x0.5 mm ²		
SM2*	Exhaust damper drive 3 position	3x0.5 mm ²		
SM2*	Exhaust damper drive 2 position	2x0.5 mm ²		
RT1	Outdoor temperature sensor	2x0.25 mm ²		up to 10 m

*Is not included in the delivery set.

** The unit is delivered with a Th Tune remote controller at the customer request

TECHNICAL MAINTENANCE



**DISCONNECT THE UNIT FROM POWER SUPPLY BEFORE ANY MAINTENANCE OPERATIONS!
MAKE SURE THE UNIT IS DISCONNECTED FROM POWER MAINS BEFORE REMOVING THE PROTECTION.**



**PRIOR TO COMMENCING ANY TECHNICAL MAINTENANCE PUT UP A PROHIBITORY SIGN ON THE FAN STARTING PANEL:
"DO NOT SWITCH ON! MEN AT WORK!"**



AVOID LIQUID SPILLS ON THE MOTOR! DO NOT USE AGGRESSIVE SOLVENTS AND SHARP OBJECTS FOR CLEANING!

Maintenance operations of the unit are required 3-4 times per year. They include general cleaning of the unit and the following operations:

1. Filter maintenance (3-4 times per year).

Dirty filters increase air flow resistance, which leads to a decrease in the supply of supply air to the room and creates preconditions for occurrence of faults. Filters should be replaced as they become dirty, but no less than 3-4 times a year.

To replace the filters, remove the cover of the unit casing (item 2 in the «Design and operating principle» section).

Rotate the lock that holds the filter. Carefully remove the dirty filter.

Install new filters and cover in reverse order.

For new filters, contact the Seller.

2. Fan maintenance (once per year).

Even in case of regular maintenance of the filters, some dust may accumulate inside the fans and reduce the fan performance and supply air flow. Clean the fans with a soft brush or cloth. Do not use water, aggressive solvents, or sharp objects as they may damage the impeller.

3. Technical maintenance of air duct system (every 5 years).

Even regular fulfilling of all the maintenance operations prescribed above may not completely prevent dirt accumulation in the air ducts, which reduces the system capacity. Duct maintenance means regular cleaning or replacement.

4. Control unit maintenance (as required).

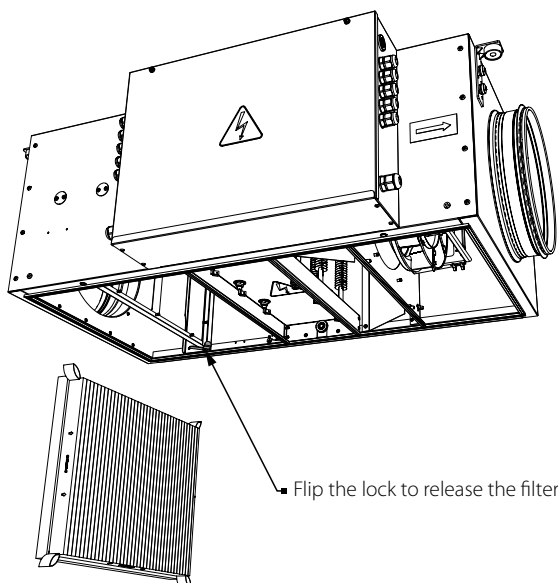

TROUBLESHOOTING

Problem	Possible reasons	Troubleshooting
The unit does not start.	No power supply.	Make sure the power supply line is connected correctly, otherwise troubleshoot a connection error.
	Jammed motor.	Disconnect the fan from power supply. Troubleshoot the motor jamming. Restart the unit.
	The fan has overheated.	Disconnect the fan from power supply. Eliminate the cause of overheating. Restart the unit.
Automatic circuit breaker tripping following the unit turning on.	Overcurrent as a result of short circuit in the electric circuit.	Switch off the unit. Contact the Seller.
Air heating does not work. Air temperature at the unit outlet is lower than the set one.	Overheating protection thermostat with a high threshold and manual return has been activated.	Contact the Seller.
Noise, vibration or reduced air flow.	The fan impeller is soiled.	Clean the impeller.
	The fan or casing screw connection is loose.	Tighten the screw connection of the fan or the casing against stop.
	The ventilation system components (air ducts, diffusers, louvre shutters, grilles) are clogged or damaged.	Clean or replace the ventilation system components (air ducts, diffusers, louvre shutters, grilles).

Make sure that the U-trap is filled with water and the drain pipes are frost protected.

If troubleshooting steps have failed, contact the Seller of the product.

In case of faults not described in the table, contact the Seller for further information.

STORAGE AND TRANSPORTATION REGULATIONS

- Store the unit in the manufacturer's original packaging box in a dry closed ventilated premise with temperature range from +5 °C to + 40 °C and relative humidity up to 70 %.
- Storage environment must not contain aggressive vapors and chemical mixtures provoking corrosion, insulation, and sealing deformation.
- Use suitable hoist machinery for handling and storage operations to prevent possible damage to the unit.
- Follow the handling requirements applicable for the particular type of cargo.
- The unit can be carried in the original packaging by any mode of transport provided proper protection against precipitation and mechanical damage. The unit must be transported only in the working position.
- Avoid sharp blows, scratches, or rough handling during loading and unloading.
- Prior to the initial power-up after transportation at low temperatures, allow the unit to warm up at operating temperature for at least 3-4 hours.

MANUFACTURER'S WARRANTY

The product is in compliance with EU norms and standards on low voltage guidelines and electromagnetic compatibility. We hereby declare that the product complies with the provisions of Electromagnetic Compatibility (EMC) Directive 2014/30/EU of the European Parliament and of the Council, Low Voltage Directive (LVD) 2014/35/EU of the European Parliament and of the Council and CE-marking Council Directive 93/68/EEC. This certificate is issued following test carried out on samples of the product referred to above.

The manufacturer hereby warrants normal operation of the unit for 24 months after the retail sale date provided the user's observance of the transportation, storage, installation, and operation regulations. Should any malfunctions occur in the course of the unit operation through the Manufacturer's fault during the guaranteed period of operation, the user is entitled to get all the faults eliminated by the manufacturer by means of warranty repair at the factory free of charge. The warranty repair includes work specific to elimination of faults in the unit operation to ensure its intended use by the user within the guaranteed period of operation. The faults are eliminated by means of replacement or repair of the unit components or a specific part of such unit component.

The warranty repair does not include:

- routine technical maintenance
- unit installation/dismantling
- unit setup

To benefit from warranty repair, the user must provide the unit, the user's manual with the purchase date stamp, and the payment paperwork certifying the purchase. The unit model must comply with the one stated in the user's manual. Contact the Seller for warranty service.

The manufacturer's warranty does not apply to the following cases:

- User's failure to submit the unit with the entire delivery package as stated in the user's manual including submission with missing component parts previously dismantled by the user.
- Mismatch of the unit model and the brand name with the information stated on the unit packaging and in the user's manual.
- User's failure to ensure timely technical maintenance of the unit.
- External damage to the unit casing (excluding external modifications as required for installation) and internal components caused by the user.
- Redesign or engineering changes to the unit.
- Replacement and use of any assemblies, parts and components not approved by the manufacturer.
- Unit misuse.
- Violation of the unit installation regulations by the user.
- Violation of the unit control regulations by the user.
- Unit connection to power mains with a voltage different from the one stated in the user's manual.
- Unit breakdown due to voltage surges in power mains.
- Discretionary repair of the unit by the user.
- Unit repair by any persons without the manufacturer's authorization.
- Expiration of the unit warranty period.
- Violation of the unit transportation regulations by the user.
- Violation of the unit storage regulations by the user.
- Wrongful actions against the unit committed by third parties.
- Unit breakdown due to circumstances of insuperable force (fire, flood, earthquake, war, hostilities of any kind, blockades).
- Missing seals if provided by the user's manual.
- Failure to submit the user's manual with the unit purchase date stamp.
- Missing payment paperwork certifying the unit purchase.



FOLLOWING THE REGULATIONS STIPULATED HEREIN WILL ENSURE A LONG AND TROUBLE-FREE OPERATION OF THE UNIT



USER'S WARRANTY CLAIMS SHALL BE SUBJECT TO REVIEW ONLY UPON PRESENTATION OF THE UNIT, THE PAYMENT DOCUMENT AND THE USER'S MANUAL WITH THE PURCHASE DATE STAMP

CERTIFICATE OF ACCEPTANCE

Unit Type	Single-block air supply unit
Model	
Serial Number	
Manufacture Date	
Quality Inspector's Stamp	

SELLER INFORMATION

Seller	
Address	
Phone Number	
E-mail	
Purchase Date	
This is to certify acceptance of the complete unit delivery with the user's manual. The warranty terms are acknowledged and accepted.	
Customer's Signature	

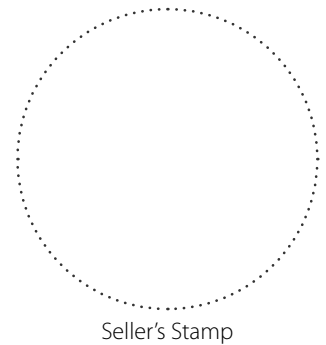

INSTALLATION CERTIFICATE

The _____ unit is installed pursuant to the requirements stated in the present user's manual.

Company name	
Address	
Phone Number	
Installation Technician's Full Name	
Installation Date:	Signature:
The unit has been installed in accordance with the provisions of all the applicable local and national construction, electrical and technical codes and standards. The unit operates normally as intended by the manufacturer.	
Signature:	

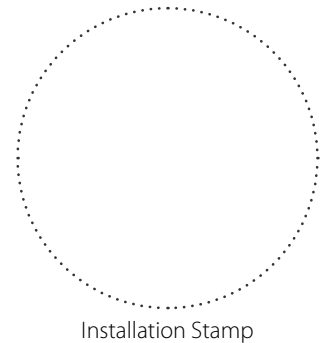

WARRANTY CARD

Unit Type	Single-block air supply unit
Model	
Serial Number	
Manufacture Date	
Purchase Date	
Warranty Period	
Seller	

