

Sensor speed switch

SGR-3/1

DESCRIPTION

The sensor speed switch SGR-3/1 is designed for speed switching in multi-speed ventilation units and domestic fans. The speed switch has a sensor panel with three buttons for speed control.

TECHNICAL DATA

Supply voltage	110-240 V, 50-60 Hz
Maximum connected load current	1 A
Cable cross section	from 0.35 mm ² to 1 mm ²
Temperature range	from -10 °C up to +45 °C
Humidity range	from 5 % up to 80 % (no condensate)
Service life	100 000 switching operations
Ingress Protection Rating	IP30
Weight	138 g



MOUNTING

WARNING!

Make sure that the switch is not damaged. Do not operate a damaged switch! Do not install a switch on an uneven surface!
Do not apply excessive forces to avoid the product deformation.
Do not expose the unit to severe temperature fluctuations.
A sudden change in temperature (e.g. when installing the unit indoors soon after bringing it in from the outdoor cold) may cause condensation of humidity and malfunction of the unit. After transport store the unit in a warm room at least 2 hours before using it.

Mounting sequence of the sensor speed switch:

- Unfasten gently the front panel latches of the switch.
- Remove the front panel.
- Route the cable in the wall to the panel mounting place.
- Attach the back panel to the wall through the fastening openings.
- Install the front panel on the latches.

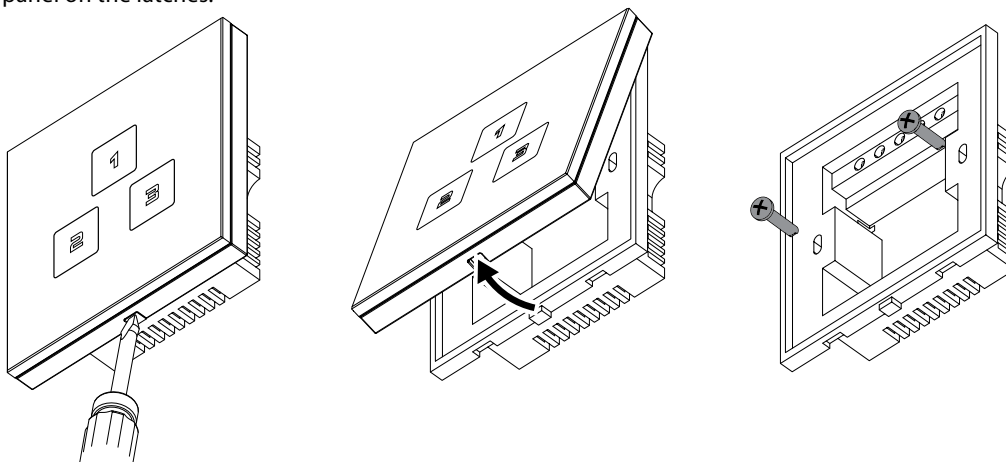

OVERALL AND CONNECTING DIMENSIONS, mm

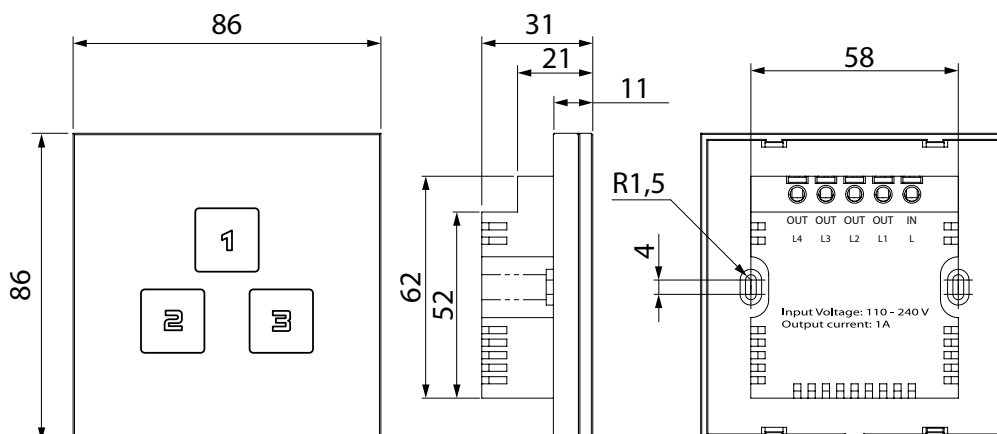

ELECTRIC CONNECTIONS

WARNING!

All the operations with the products are allowed after power supply cutoff.
 All mounting, addition, modification and maintenance operation for electric equipment must be performed by qualified electricians with a work permit for electric operations.
 Connect the switch to ventilation units and domestic fans in compliance with the wiring diagram below.

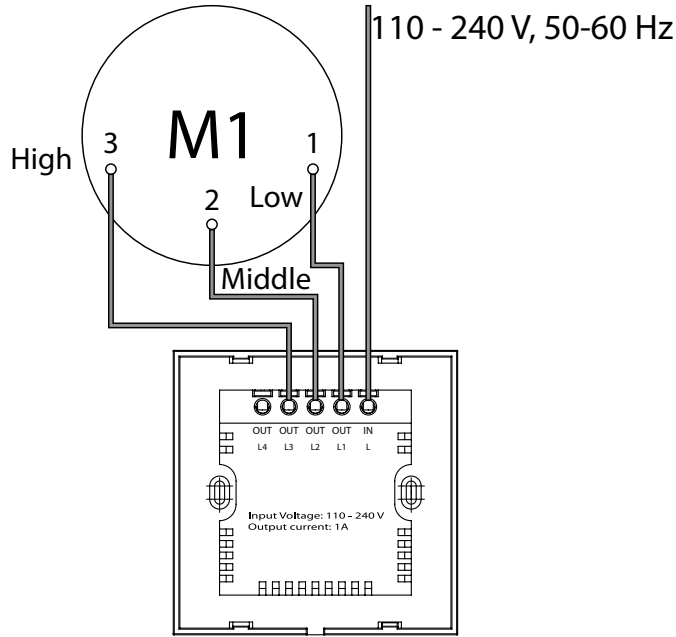

CONTROL

- To activate the required speed of the connected ventilation equipment, touch the button with a respective speed marking.
 - 1 speed;
 - 2 speed;
 - 3 speed;
- For speed switching, touch a button with respective speed indication.
- To turn the product off touch the respective current fan speed button again. The respective current speed button.

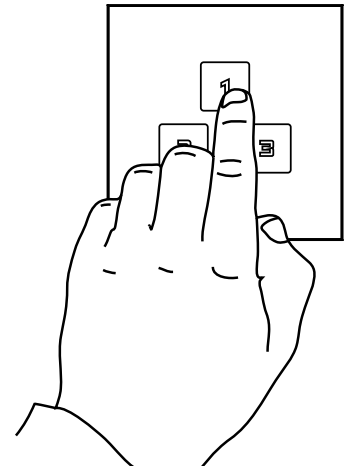

WARRANTY

Warranty period is 12 months since the sales date.
 The Supplier bears no responsibility for any damages of the product incurred by violation of the transportation rules, product misuse, unauthorized modification or repair.

THE SENSOR SPEED SWITCH SGR-3/1
 is duly recognized as serviceable.

Approval mark _____ Manufacturing date _____

Sold
 (name and stamp of the trade company) _____

Date of sale _____