



SPEED SWITCH



CDP-3/5



OPERATION MANUAL

BLAUBERG Ventilatoren GmbH is happy to offer your attention the speed switch CDP-3/5.

INTRODUCTION

The present operation manual contains technical description, technical data sheets, operation and mounting guidelines, safety precautions and warnings for safe and correct operation of the device.

Read carefully the operation manual, especially the safety requirements before mounting and start-up of the device.

Keep the operation manual available as long as you use the device.

GENERAL

The CDP-3/5 speed switch is designed for switching on/off and speed switching of ventilation units and fans.

SAFETY RULES

Cut off power supply to the device prior to any operations.

All mounting and maintenance operations must be carried out by duly qualified electricians with a valid electrical work permit for electric operations after careful study of the user's manual.

Misuse of the device or any unauthorized modification are not allowed.

Follow the manual guidelines to ensure trouble-free operation and long service life of the device.

STORAGE AND TRANSPORTATION RULES

Transportation is allowed by any vehicle provided the product is transported in the original package and is protected against weather and mechanical damages.

Store the delivered product in the manufacturer's original packing box in a dry ventilated premise.

The storage environment must not be subjected to any aggressive and/or chemical evaporations, admixtures, foreign objects that may provoke corrosion and damage connection tightness.

Store the product in an environment with minimized risk of mechanical damages, temperature and humidity fluctuations at the ambient temperature from +5°C up to +40°C.

MANUFACTURER'S WARRANTY

The product complies with the requirements according to the EU norms and directives, to the relevant EU-Low Voltage Equipment Directives, EU-Directives on Electromagnetic Compatibility.

The product complies with the requirements according to the EU norms and directives, to the relevant EU-Low Voltage Equipment Directives, EU-Directives on Electromagnetic Compatibility. We hereby declare that the following product complies with the essential protection requirements of Electromagnetic Council Directive 2004/108/EC, 89/336/EEC and Low Voltage Directive 2006/95/EC, 73/23/EEC and CE-marking Directive 93/68/EEC on the approximation of the laws of the Member States relating to electromagnetic compatibility.

The manufacturer hereby warrants normal operation of the product over the period of 2 years from the retail sale date provided observance of the installation and operation regulations.

In case of failure due to manufacturing fault during the warranty period the consumer has the right for the device repair or exchange.

The replacement is offered by the Seller.

If case of no confirmation of the sale date, the warranty period shall be calculated from the manufacturing date.

The MANUFACTURER shall not be liable for any damage resulting from any product misuse of or gross mechanical interference with it.

The MANUFACTURER is not responsible for the damages resulted due to the use of third party equipment or to third party equipment.



WARNING

The product is not allowed for use by children and persons with reduced physical, mental or sensory capacities, without proper practical experience or expertise, unless they are controlled or instructed on the product operation by the person(s) responsible for their safety. Supervise the children and do not let them play with the product.



WARNING

Do not dispose in domestic waste. The product contains in part material that can be recycled and in part substances that should not end up as domestic waste. Dispose the product once it has reached the end of its working life according to the regulations valid in your country.

DELIVERY SET

- ✓ Speed switch CDP-3/5;
- ✓ Operation manual;
- ✓ Packing box.

TECHNICAL DATA

Table 1. Technical data

Model	Parameters						
	Supply voltage, 50-60 Hz [V]	Max. load current [A]	Max. output power [VA]	Operating temperature range [°C]	Operating humidity range [%]	Ingress Protection Rating	Weight [g]
CDP-3/5	230	3	600	from -10 up to +40	max. 80	IP40	130

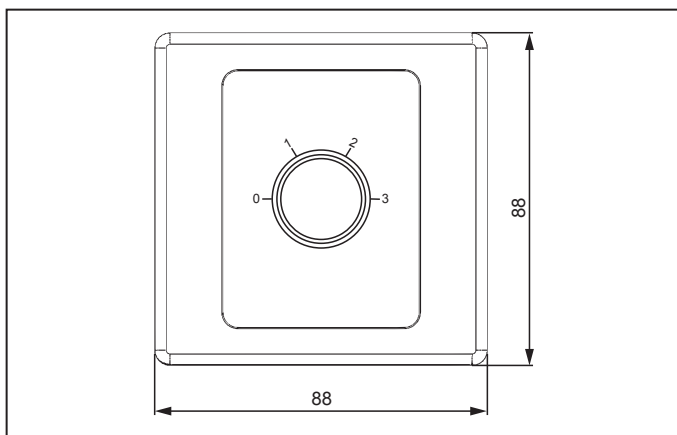

Fig. 1. Overall dimensions

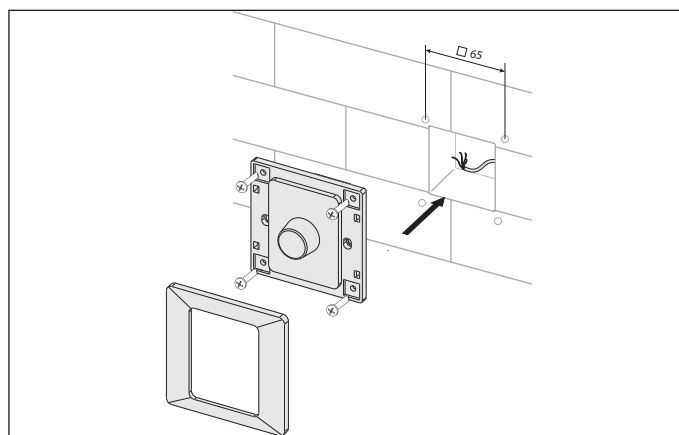

Fig. 2. Mounting

MOUNTING



WARNING

Make sure that the speed switch is not damaged. Do not use a damaged speed switch Do not install the speed switch on an uneven surface! While tightening the screws avoid overtightening not to damage the device.

Mounting sequence of the speed switch, fig. 2:

1. Pull and remove the speed switch knob.
2. Carefully undo the latches on the front panel with a screwdriver and remove it.
3. Route the cable to the installation place of the speed switch.
4. Connect the wires to the speed switch and fix the back panel to the wall through the fixing holes.
5. Install the front panel and the speed switch knob.

CONNECTION TO POWER MAINS



WARNING

Cut off power supply to the speed switch prior to any operations with the speed switch. All mounting and servicing operations are allowed for duly qualified electricians with valid electrical work permit for electric operations after careful study of the present operation manual. For connection of the speed switch to ventilation units and fans follow the wiring diagram, fig. 3.

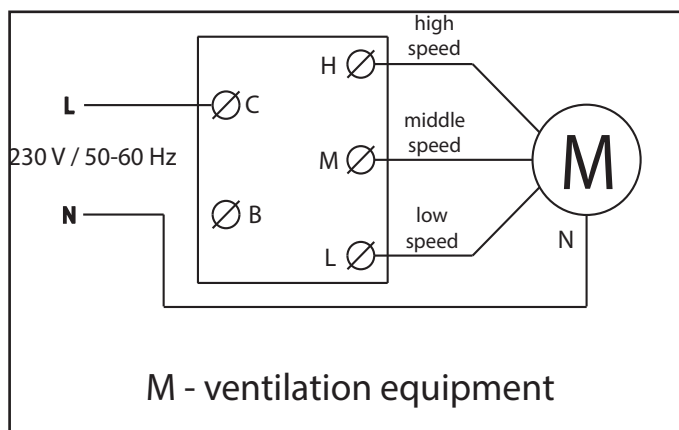

Fig. 3. Wiring diagram

Подключение переключателя к вентиляционным установкам и вентиляторам производится согласно схеме, указанной на Рис.3.

CONTROL

To activate the required speed of the connected ventilation equipment rotate the speed switch knob clockwise and position it according to the required speed marking, fig. 4:

- 1 — low speed;
- 2 — middle speed;
- 3 — high speed.

To turn the connected ventilation equipment off rotate the speed switch knob counterclockwise and set it into «0» position, the maximum left position.

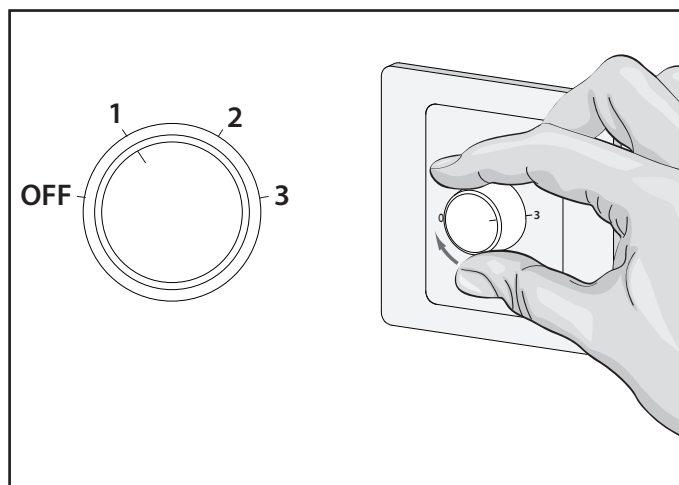

Fig. 4. Control

ACCEPTANCE CERTIFICATE

Speed switch

CDP-3/5	
---------	--

is recognizes as serviceable.

Approval mark

Manufacturing date _____

WARRANTY CARD

CDP-3/5	
---------	--

SELLER

SALES DATE

REPRESENTATIVE IN EU

BLAUBERG Ventilatoren GmbH
Aidenbachstr. 52a
D-81379 Munich, Germany

