

OMEGA ONE

DESIGN KONZEPT SYSTEM

Features



- Additional rubber seal realized by two-component molding allows the fans to be used in Zone 1.
- Advanced 7-blade impeller aerodynamic profile provides even better performance and lower noise level.
- One of the quietest and most economical fans on the market due to its mixed-flow impeller, special streamer and modern electric motor.
- No drafts due to a built-in back valve.
- 40 000 hours of continuous operation.
- Both wall and ceiling mounting are possible.
- Compatible with all decorative panels of the **Design Konzept** system.



Air flow:
up to 95 m³/h
26 l/s



Power:
from 8 W
SFP:
from 0.3 W/l/s



Noise level:
from 27 dBA



Options

Model	Omega One 100			
	S	T	TR	H
Option				
Pull cord switch	•			
Turn-on delay timer			•	
Turn-off delay timer		•	•	•
Humidity sensor				•

- Turn-on delay timer**
 - Adjustable delay from 10 seconds to 2 minutes.
- Turn-off delay timer**
 - Adjustable delay from 2 to 30 minutes.
- Humidity sensor**
 - Humidity sensor activation threshold is adjustable from 60 % to 90 %.

Overall dimensions and mounting

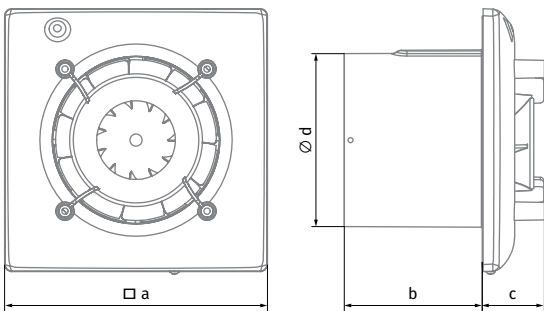

Dimensions [mm]	a	∅ d	b	c
Omega One 100	150	99	79	36

Designation key		
Omega One	100	H
Model	Spigot ∅	Option

Technical data

Model	Omega One 100
Voltage [V]	220–240
Frequency [Hz]	50
Power [W]	8
Current [A]	0.05
RPM [min ⁻¹]	2154
Air flow [m ³ /h] (l/s)	95 (26)
SFP [W/l/s]	0.3
Sound pressure level [dBA]*	27

* Sound pressure level measured in free space at a distance of 3 meters from the fan.



CE IP44 Zone 1