



INLINE MIXED-FLOW FANS
VENTS TT PRO EC
User's manual

TT PRO EC

EN



CONTENTS

Delivery set	6
Brief description	6
Operation guidelines	6
Designation key	7
Installation	8
Control modes	9
Maintenance.....	10
Storage and transportation regulations.....	10
Manufacturer's warranty	11

This user's manual is a main operating document, intended for technical, maintenance, and operating staff.

The manual contains information about the purpose, technical details, operating principle, design, and installation of the TT PRO EC unit and all of its modifications.

Technical and maintenance staff must have theoretical and practical training in the field of ventilation systems and should be able to work in accordance with workplace safety rules as well as construction norms and standards applicable in the territory of the country.

The information in this user's manual was correct at the time of the document's preparation.

The Company reserves the right to modify the technical characteristics, design, or configuration of its products at any time in order to incorporate the latest technological developments.

No part of this publication may be reproduced, stored in a retrieval system, or transmitted, in any form or by any means in any information search system or translated into any language in any form without the prior written permission of the Company.



**READ THE USER'S MANUAL CAREFULLY BEFORE PROCEEDING WITH INSTALLATION WORKS.
COMPLIANCE WITH THE MANUAL REQUIREMENTS ENSURES RELIABLE OPERATION AND LONG
SERVICE LIFE OF THE UNIT.
KEEP THE USER'S MANUAL AVAILABLE AS LONG AS YOU USE THE UNIT. YOU MAY NEED TO RE-
READ THE INFORMATION ON THE PRODUCT SERVICING.**



FOLLOW THE USER'S MANUAL REQUIREMENTS TO ENSURE DURABLE AND TROUBLE-FREE OPERATION OF THE UNIT.

Disconnect the unit from power supply prior to any connection, servicing, maintenance, and repair operations.

Only qualified electricians with a work permit for electrical units up to 1000 V are allowed for installation and maintenance. The present user's manual should be carefully read before beginning works.

- Single-phase power mains must comply with the acting local electrical norms and standards.
- Fixed electrical wiring must be equipped with an automatic circuit breaker.
- The unit must be connected to power mains through a QF automatic circuit breaker integrated into the fixed wiring system. The gap between the circuit breaker contacts on all poles must be not less than 3 mm. Check the unit for any visible damages of the impeller and the casing before starting installation. The casing internals must be free of any foreign objects that can damage the impeller blades.
- While mounting the unit, avoid compression of the casing! Deformation of the casing may result in the motor jam and noisy operation. Misuse of the unit and any unauthorised modifications are not allowed.
- Take steps to prevent ingress of smoke, carbon monoxide, and other combustion products into the room through open chimney flues or other fire-protection devices. Sufficient air supply must be provided for proper combustion and exhaust of gases through the chimney of fuel burning

equipment to prevent back drafting. Transported air must not contain any dust or other solid impurities, sticky substances, or fibrous materials.

- Do not use the unit in a hazardous or explosive environment containing spirits, gasoline, insecticides, etc.
- Do not close or block the intake or extract vents in order to ensure the efficient air flow.
- Do not sit on the unit and do not put objects on it.
- The unit is allowed to be used by children aged from 8 years old and above and persons with reduced physical, sensory, or mental capabilities or no experience and knowledge provided that they have been given supervision or instruction regarding safe use of the unit and understand the risks involved.
- Do not allow children to play with the unit.

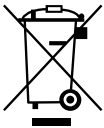

**THE PRODUCT MUST BE DISPOSED SEPARATELY AT THE END OF ITS SERVICE LIFE.
DO NOT DISPOSE THE UNIT AS UNSORTED MUNICIPAL WASTE.**

DELIVERY SET

Fan	— 1 pc.
Screws and dowels	— 4 pcs.
Plastic screwdriver	— 1 pc.
User's manual	— 1 pc.
Packing box	— 1 pc.

BRIEF DESCRIPTION

The product described herein is a mixed-flow inline fan for supply or extract ventilation of premises heated during winter time. The fan is designed for connection to \varnothing 100, 125, 150, 160, 200, 250 and 315 mm air ducts.

The fan is equipped with an energy-efficient and high-performance electronically commutated motor (EC motor) and with a built-in speed controller.

An external control unit can be connected to the fan.

The fan design is constantly being improved, thus some models may be slightly different from those described in this manual.

OPERATION GUIDELINES

The fan is rated for connection to single-phase AC 220-240 V/50 (60) Hz power mains.

The fan is rated for continuous operation.

Air motion direction in the system must match the pointer on the fan casing.

Hazardous parts access and water ingress protection rating is IPX4.

The fan is rated for operation at the ambient temperature ranging from +1 °C up to +45 °C.

Transported air temperature must not exceed +60 °C.

The ventilator is rated as a class II electric appliance.

DESIGNATION KEY

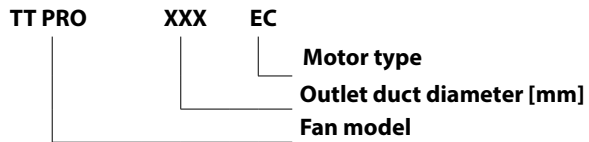

INSTALLATION

The fan is suitable both for horizontal or vertical mounting on the floor, on the wall or on the ceiling (Fig. 1).

While mounting the fan provide extra protection against water ingress, such as:

1. For the top mounting: install an outer protecting hood above (Fig. 2).
2. For any mounting position: connect an air duct on both sides of the fan (Fig. 2).

Mounting sequence for various fan models is shown in Fig. 3-8.

Fan wiring diagram is shown in Fig. 9-14.

External control unit wiring diagram is shown in Fig. 15-20.

The R1 potentiometer, the XP1 and XP2 terminals and the DIP switch installation locations on the control board are shown in Fig. 22-23.

The fan wiring diagram is shown in Fig. 25.

TERMINAL DESIGNATIONS ON WIRING DIAGRAMS

Обозначение автоматического выключателя на схеме



Клеммник для сети 220-240 В / 50-60 Гц



Автоматический выключатель



Клеммник для подключения внешнего регулятора скорости



Внутренний регулятор скорости



DIP-переключатель



Внешний регулятор скорости



QF	external circuit breaker
XP1	terminal block for 220-240 V/50-60 Hz power mains
XP2	terminal block for connection of an external speed controller
SW	DIP switch
R1	internal speed controller
S1	external speed controller

CONTROL MODES

There are two control modes.

The motor is controlled by sending of an external control signal from 0 to 10 V to the XP2 terminal block or by the R1 potentiometer installed on the board. Control method selection is carried out by means of the SW DIP switch:

- **DIP switch in ON position.** The control signal is set by the R1 potentiometer. Rotations are controlled from the minimum (extreme left position) to the maximum (extreme right position). When rotating clockwise, the rotations increase.
- **DIP switch in OFF position.** The control signal is set by the external control unit.

MAINTENANCE

Clean the product surfaces regularly (once in 6 months) from dust and dirt. Disconnect the fan from power mains prior to any maintenance operations. To clean the fan, use a soft cloth or a brush wetted in a mild detergent solution. Avoid water ingress to electrical components.

Wipe the unit surfaces dry after cleaning.

STORAGE AND TRANSPORTATION REGULATIONS

- Store the unit in the manufacturer's original packaging box in a dry closed ventilated premise with temperature range from +5 °C to +40 °C and relative humidity up to 70 %.
- Storage environment must not contain aggressive vapours and chemical mixtures provoking corrosion, insulation, and sealing deformation.
- Use suitable hoist machinery for handling and storage operations to prevent possible damage to the unit.
- Follow the handling requirements applicable for the particular type of cargo.
- The unit can be carried in the original packaging by any mode of transport provided proper protection against precipitation and mechanical damage. The unit must be transported only in the working position.
- Avoid sharp blows, scratches, or rough handling during loading and unloading.
- Prior to the initial power-up after transportation at low temperatures allow the unit to warm up at room temperature for at least 3-4 hours.

MANUFACTURER'S WARRANTY

The product is in compliance with EU norms and standards on low voltage guidelines and electromagnetic compatibility. We hereby declare that the product complies with the provisions of Electromagnetic Council Directive 2014/30/EU, Low Voltage Directive 2014/35/EU and CE-marking Directive 93/68/EEC. This certificate is issued following test carried out on samples of the product referred to above.

The manufacturer hereby warrants normal operation of the unit for 60 months after the retail sale date provided the user's observance of the transportation, storage, installation, and operation regulations. Should any malfunctions occur in the course of the unit operation through the Manufacturer's fault during the guaranteed period of operation, the user is entitled to get all the faults eliminated by the manufacturer by means of warranty repair at the factory free of charge. The warranty repair includes work specific to elimination of faults in the unit operation to ensure its intended use by the user within the guaranteed period of operation. The faults are eliminated by means of replacement or repair of the unit components or a specific part of such unit component.

The warranty repair does not include:

- routine technical maintenance
- unit installation/dismantling
- unit setup

To benefit from warranty repair, the user must provide the unit, the user's manual with the purchase date stamp, and the payment paperwork certifying the purchase. The unit model must comply with the one stated in the user's manual. Contact the Seller for warranty service.

The manufacturer's warranty does not apply to the following cases:

- User's failure to submit the unit with the entire delivery package as stated in the user's manual including submission with missing component parts previously dismantled by the user.
- Mismatch of the unit model and the brand name with the information stated on the unit packaging and in the user's manual.
- User's failure to ensure timely technical maintenance of the unit.
- External damage to the unit casing (excluding external modifications as required for installation) and internal

components caused by the user.

- Redesign or engineering changes to the unit.
- Replacement and use of any assemblies, parts and components not approved by the manufacturer.
- Unit misuse.
- Violation of the unit installation regulations by the user.
- Violation of the unit control regulations by the user.
- Unit connection to power mains with a voltage different from the one stated in the user's manual.
- Unit breakdown due to voltage surges in power mains.
- Discretionary repair of the unit by the user.
- Unit repair by any persons without the manufacturer's authorization.
- Expiration of the unit warranty period.
- Violation of the unit transportation regulations by the user.
- Violation of the unit storage regulations by the user.
- Wrongful actions against the unit committed by third parties.
- Unit breakdown due to circumstances of insuperable force (fire, flood, earthquake, war, hostilities of any kind, blockades).
- Missing seals if provided by the user's manual.
- Failure to submit the user's manual with the unit purchase date stamp.
- Missing payment paperwork certifying the unit purchase.



FOLLOWING THE REGULATIONS STIPULATED HEREIN WILL ENSURE A LONG AND TROUBLE-FREE OPERATION OF THE UNIT.



USER'S WARRANTY CLAIMS SHALL BE SUBJECT TO REVIEW ONLY UPON PRESENTATION OF THE UNIT, THE PAYMENT DOCUMENT AND THE USER'S MANUAL WITH THE PURCHASE DATE STAMP.

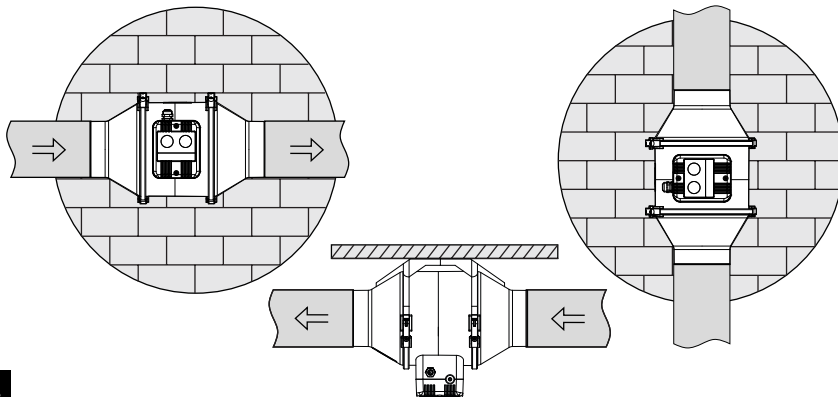

1.

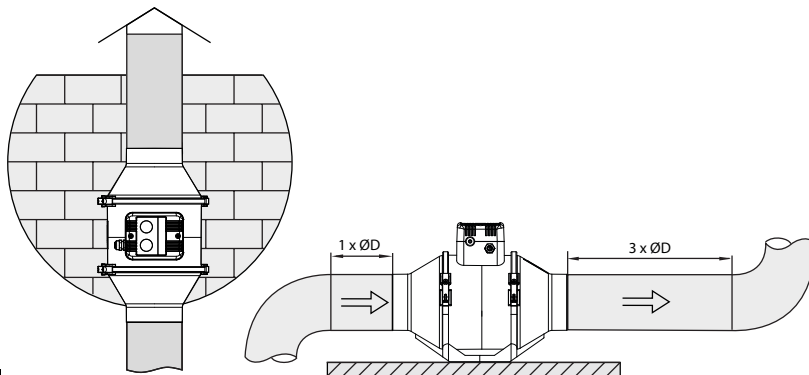

2.

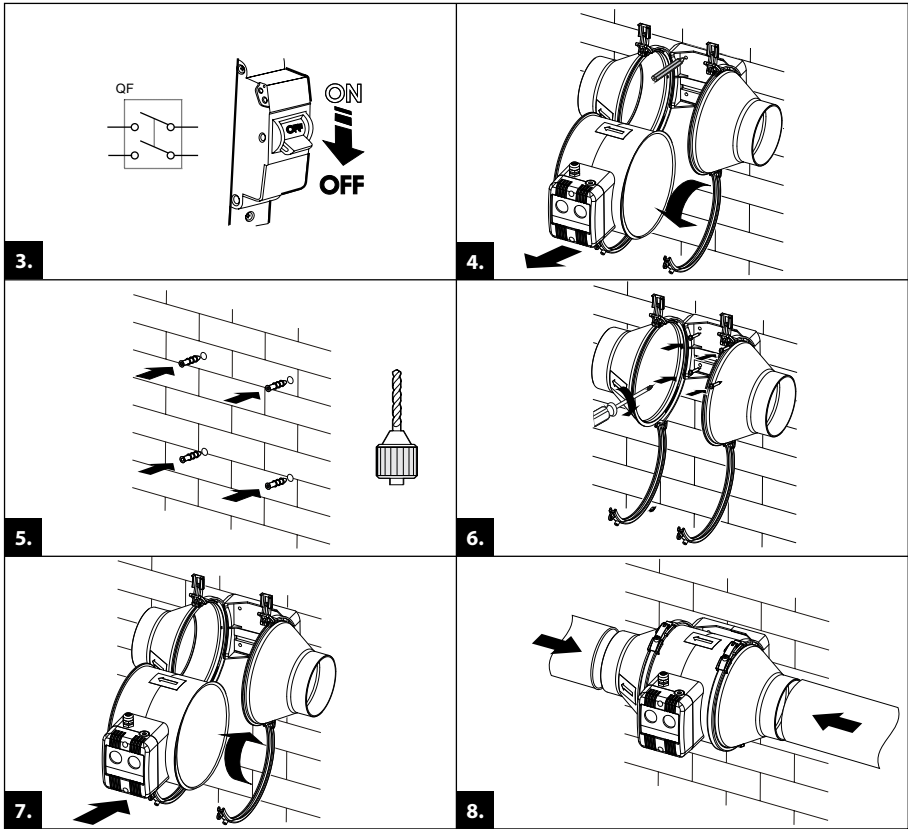

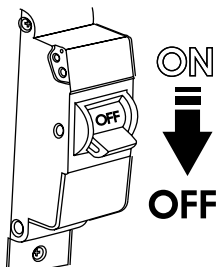

9.

Remove the front cover of the fan

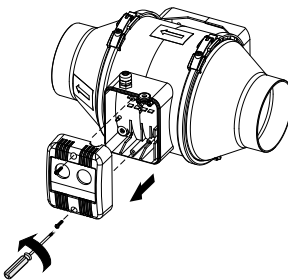

10.

Connect the power cord to the counterpart of the XP1 terminal block

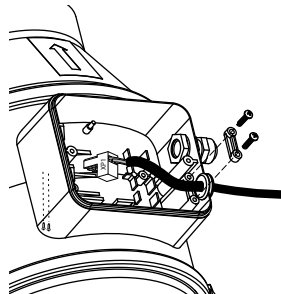

11.

Connect the XP1 terminal block counterpart to the XP1 terminal block

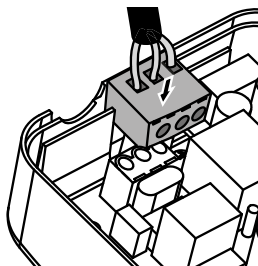

12.

Install the front cover on the fan casing

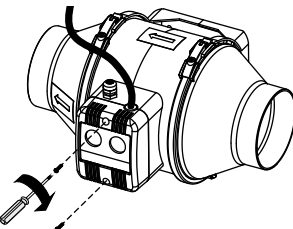

13.

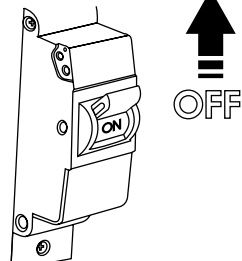

14.

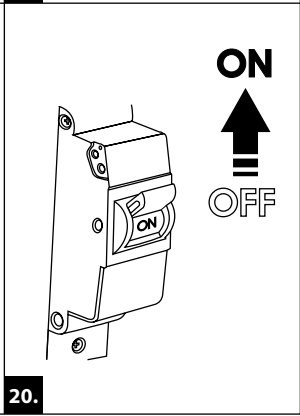
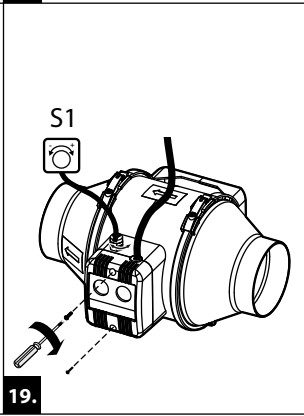
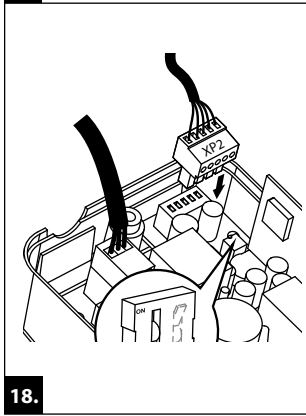
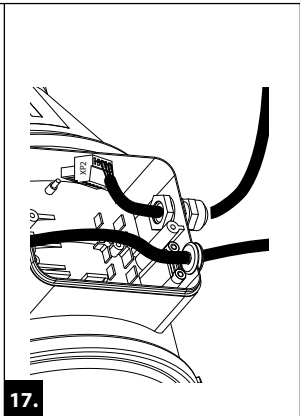
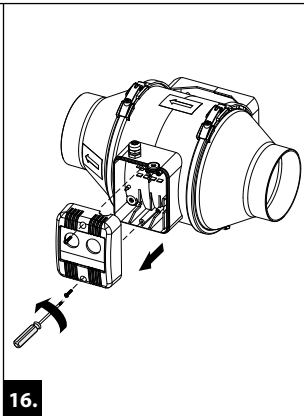
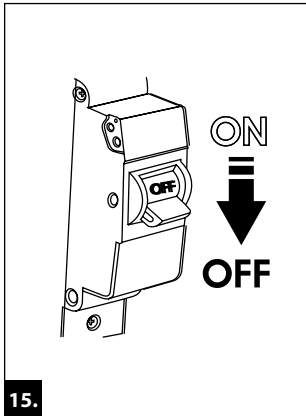

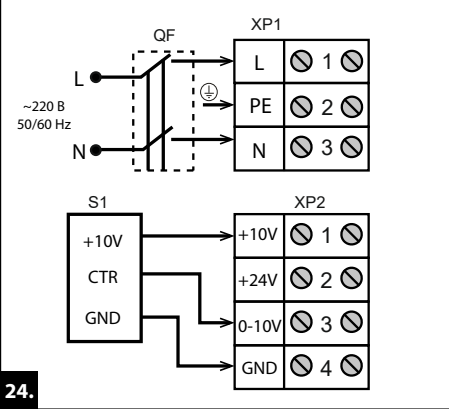
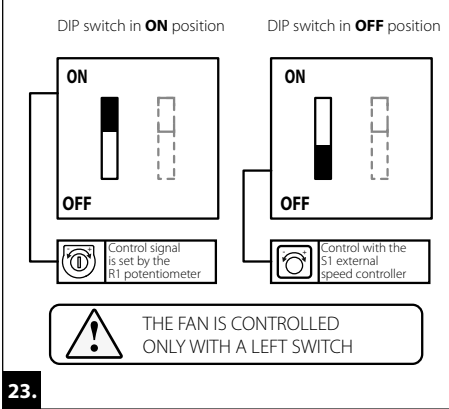
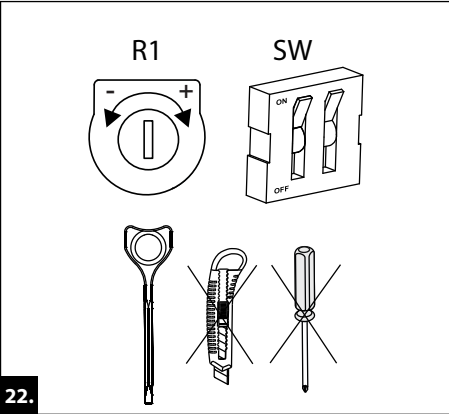
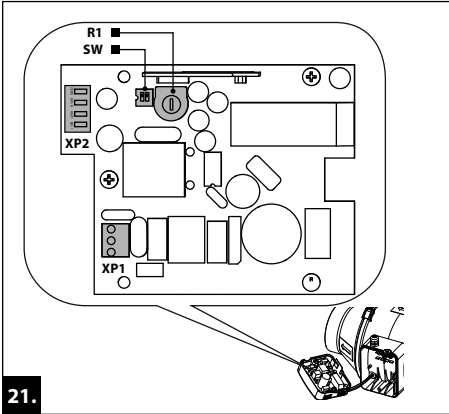

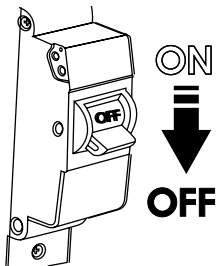

25.

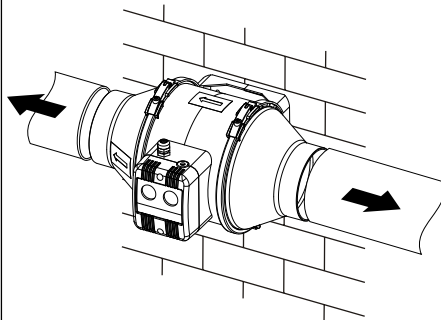

26.

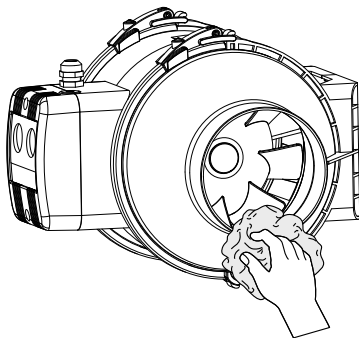

27.

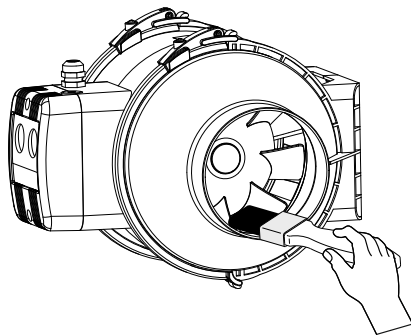

28.

Quality Inspector's Stamp

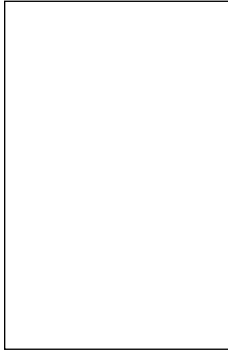

Sold by
(name and stamp of the seller)

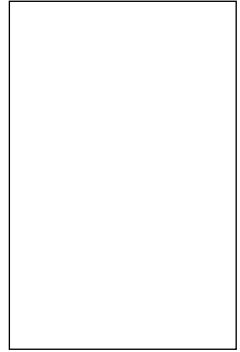

Manufacture Date

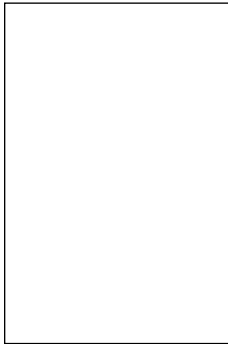

Purchase Date

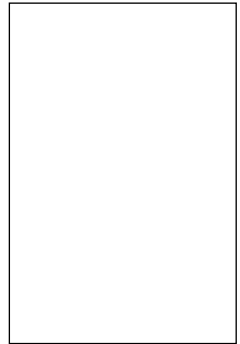

Certificate of acceptance

100

125

150

TT PRO 160 EC

200

250

315

The fan is recognized as serviceable.